Spatial Modulation Based on Reconfigurable Antennas: A New Air Interface for the Internet of Things (from theory to experimental validation)

Marco Di Renzo

Paris-Saclay University

Laboratory of Signals and Systems (L2S) – UMR8506

CNRS – CentraleSupélec – University Paris-Sud

Paris, France

marco.direnzo@l2s.centralesupelec.fr

French Science
Foundation (ANR)

**Spatial
Modulation**

*IEEE 5G Greece Summit
Thessaloniki, Greece, July 11, 2017*

USER EXPERIENCE CONTINUITY

MOBILE DATA VOLUME
10 Tb/s/km²

PEAK DATA RATE
10 Gb/s

E2E LATENCY
5 ms

MOBILITY
500 km/h

MISSION CRITICAL SERVICES

RELIABILITY
99.999%

4G

5G

SERVICE DEPLOYMENT TIME
90 minutes

NUMBER OF DEVICES
1 M/km²

ENERGY EFFICIENCY
10% of current consumption

INTERNET OF THINGS



5G Disruptive Capabilities

IoT: Optimization Space Beyond Mobiles & Sensors

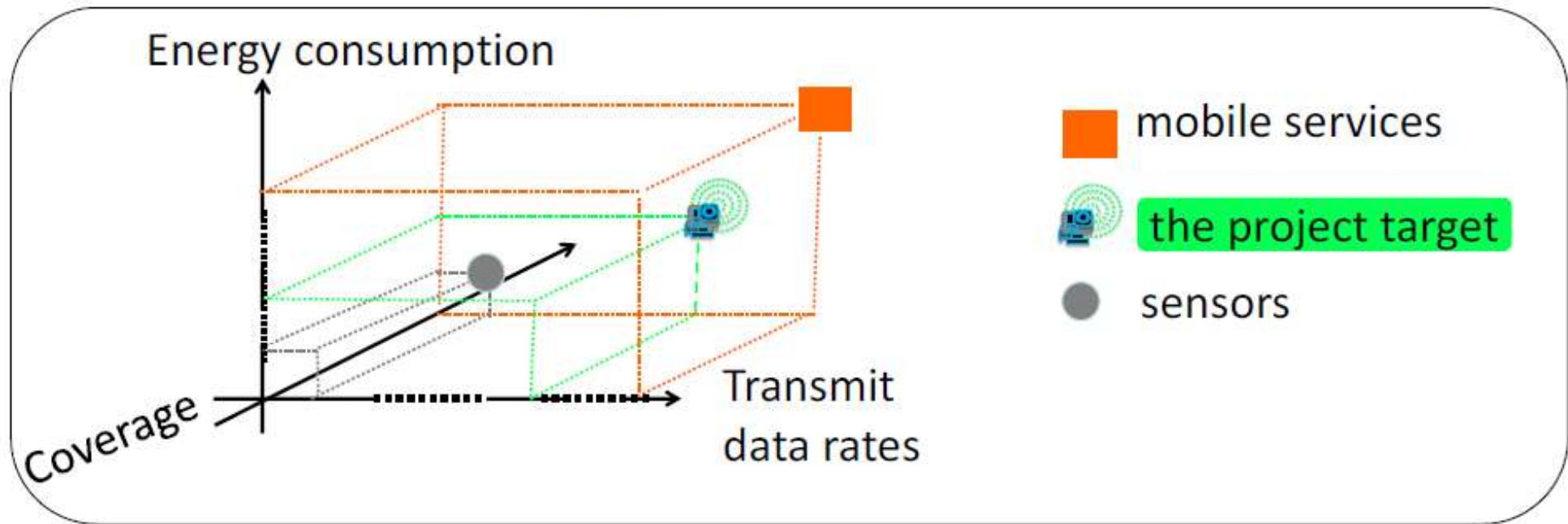

- ❑ **A new air interface for achieving the requirements of this new and emerging optimization space is needed**
 - **Rate:** in between mobile and sensor applications
 - **Complexity:** in between mobile and sensor applications
 - **Energy:** in between mobile and sensor applications
 - **Flexibility:** encompasses mobiles and sensors as special cases

An IoT Example: Cellular-Enabled Wearables

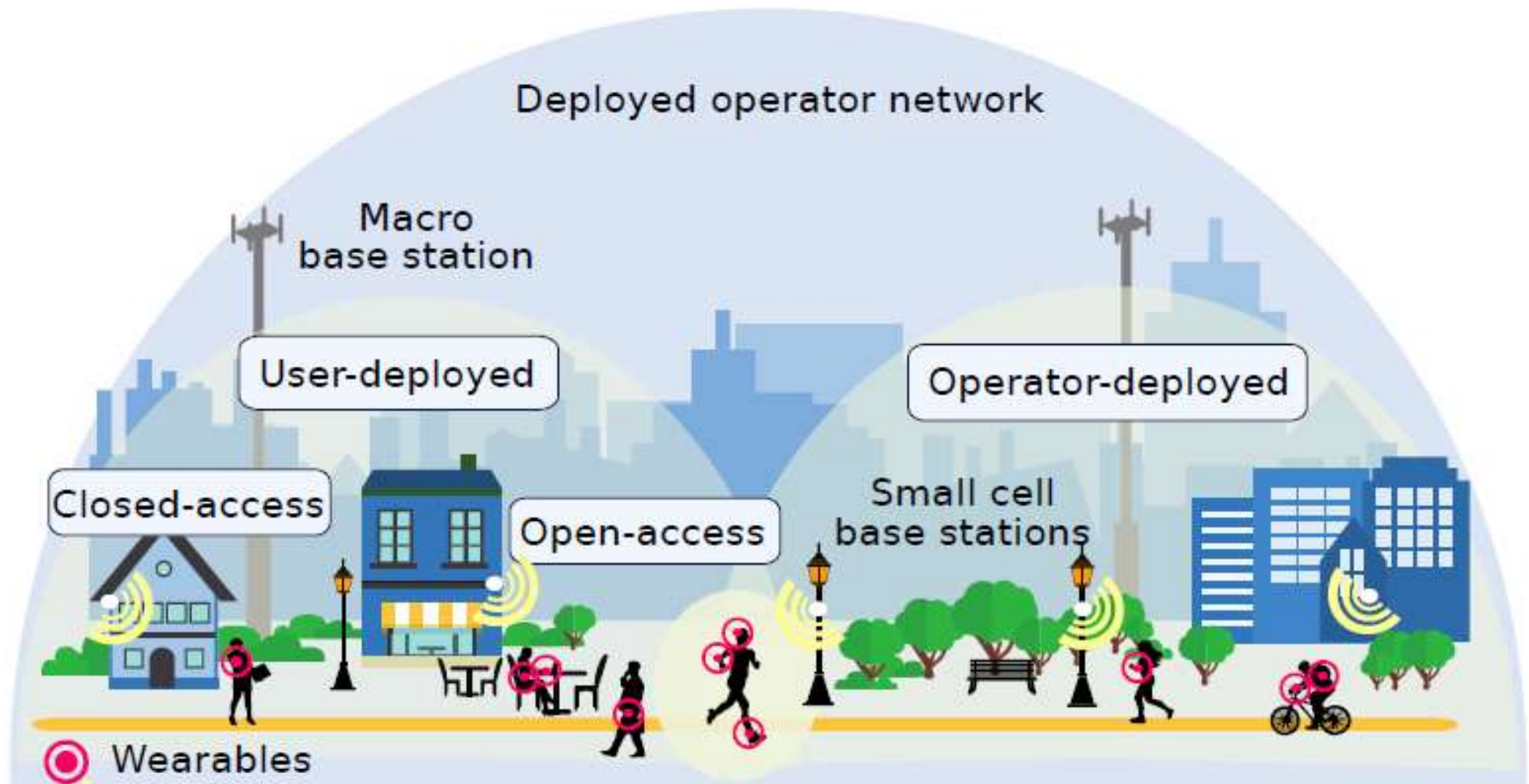

Cellular-Enabled IoT ?



Apple Watch 2: Built-in Cellular and GPS

Yeah, for now if you want an Internet connection or working GPS, your Apple Watch needs to be paired with your iPhone. In order for the Apple Watch to be a truly stand alone device, it would need both a cellular connection and built-in GPS. Of course if it had a cellular and GPS chip, you're talking about components that eat through battery life, which doesn't make the first item on our wishlist any more plausible.

Why Cellular for the IoT? A Couple of Year Ago...

[...http://www.cnet.com/news/ring-ring-its-your-watch-calling-att-bets/...](http://www.cnet.com/news/ring-ring-its-your-watch-calling-att-bets/)

Ring ring, it's your watch calling

On paper, it doesn't make sense for smartwatches to have their own independent connection. But AT&T is working to make sure it's in the mix when it comes to wearables.

Does a smartwatch need its own cellular connection?

The simple answer is, well, no. Adding a cellular radio to a watch increases the size, drains the battery faster and makes it more expensive. That's why most of the high-tech watches opt for Bluetooth for talking to a nearby smartphone.



The Timex Ironman One GPS+ will include a cellular radio with an AT&T connection.

James Martin/CNET

AT&T isn't convinced. It sees value in having an independent cellular line built into a wearable device. After all, do you really want to carry your clunky smartphone when you go on a run? And **wearable medical devices may require the kind of persistent connection only a cellular network can provide.**

Smartwatches with Cellular Connection – Now Available



The IoT Needs an Energy Efficient Cellular Connection

Use Cases Recap: The Problem of Battery Lifetime

Battery lifetime is not just a problem for the devices to perform their operations; it is also a huge problem for battery manufactures, because **battery density does not improve at the same rate** of other technologies.

❑ James Park (Fitbit CEO) declared [in a video interview during CES 2016](#) *“battery is the hardest piece of technology to advance. I think every year there’s been a few-percentage increase in power density in lithium ion cells... but you can’t bank on the fact that there will be a huge step forward in battery chemistry or battery technology”.*

❑ The challenges to increase battery lifetime are around cost. Some super thin battery with low discharge rate are already available, but their cost is prohibitive.

❑ A survey performed by TE Connectivity asked respondents which wearable functionality would increase the likelihood of purchasing a wearable or smart device in the next year. **Longer battery life was the most important feature for 49% of survey respondents.**



Spatial Modulation – An EE Air Interface for the IoT

Industrial ANR Project (Orange Labs leads, Jan. 2016)

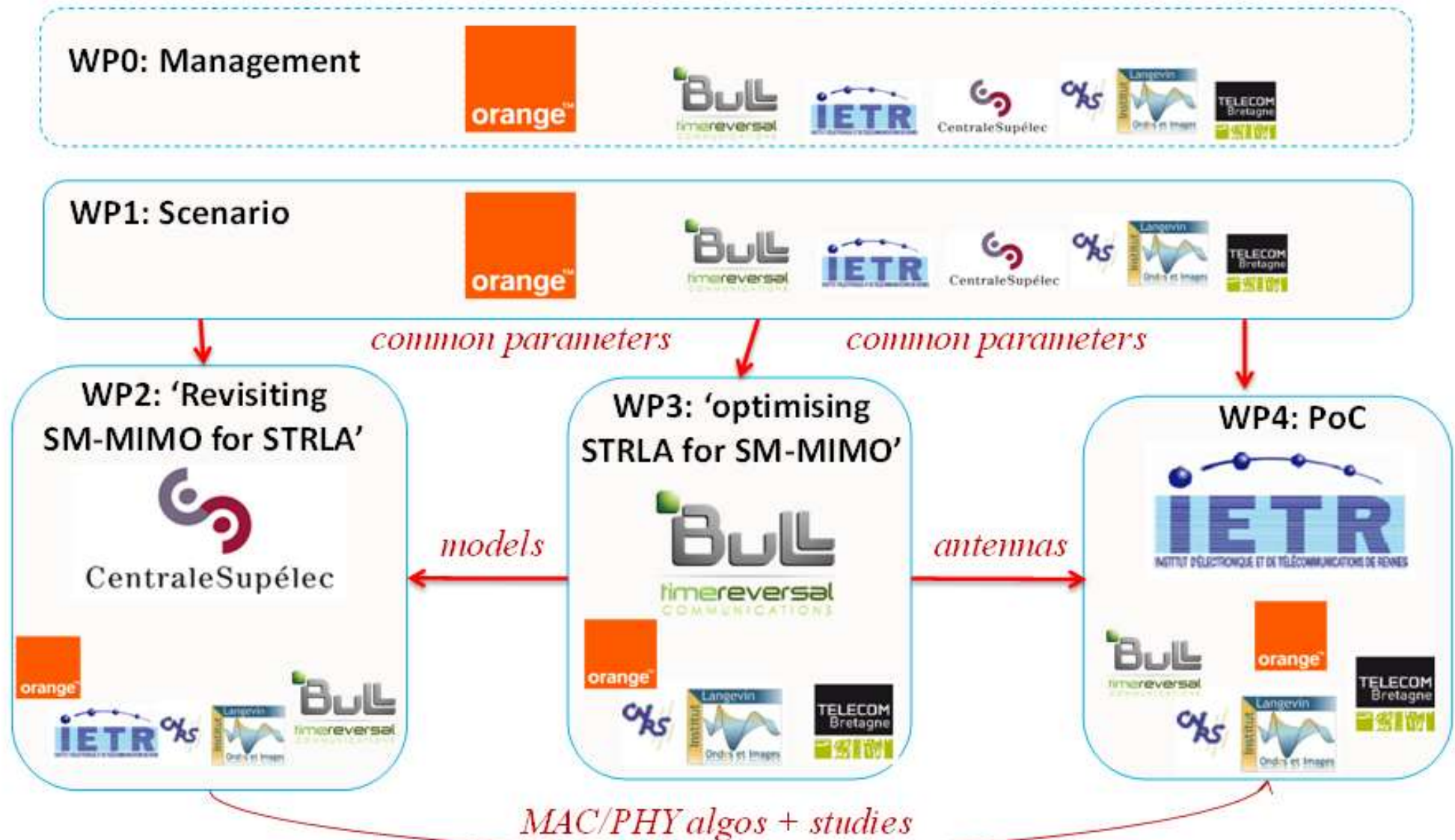
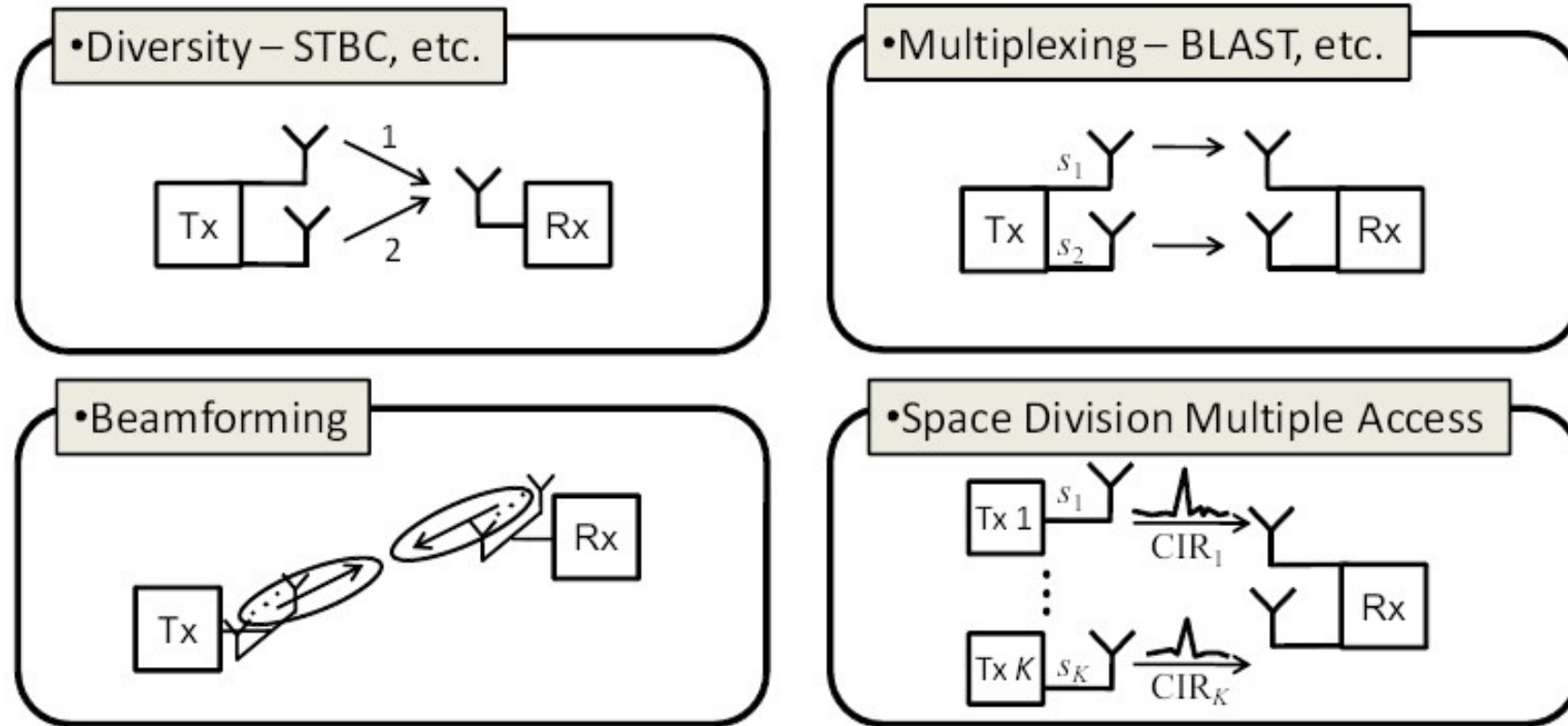

Figure 2-1: organization of the project

MIMO – Better Rate and Performance...



- ❑ Array gain (beamforming), spatial division multiple access
- ❑ Spatial multiplexing: $\text{Rate} = \min(N_t, N_r) \log_2(1 + \text{SNR})$
- ❑ Reliability: $\text{BEP} \sim \text{SNR}^{-(N_t N_r)}$

... But, What About Complexity...?

Conventional MIMO

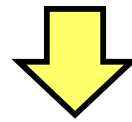
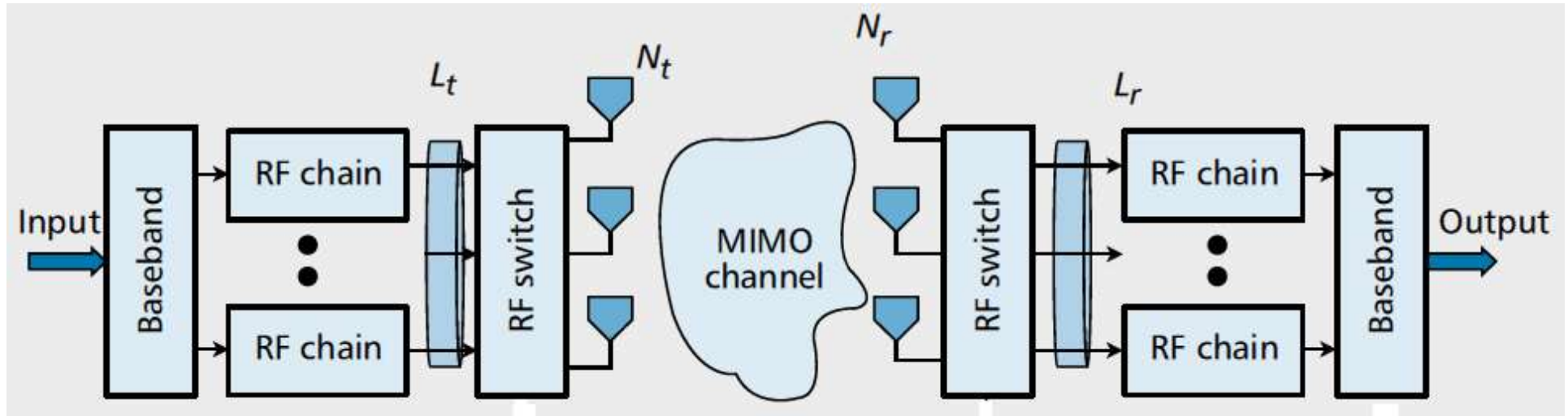

Single-RF MIMO

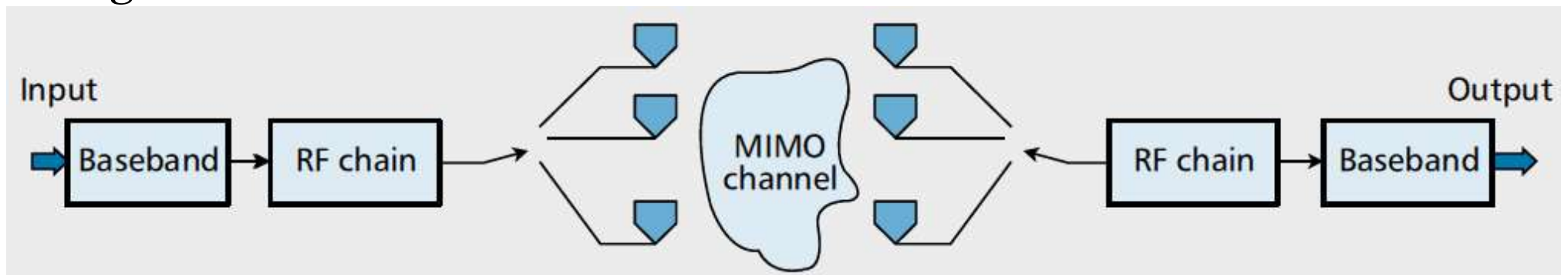

... and What About Energy Consumption ?

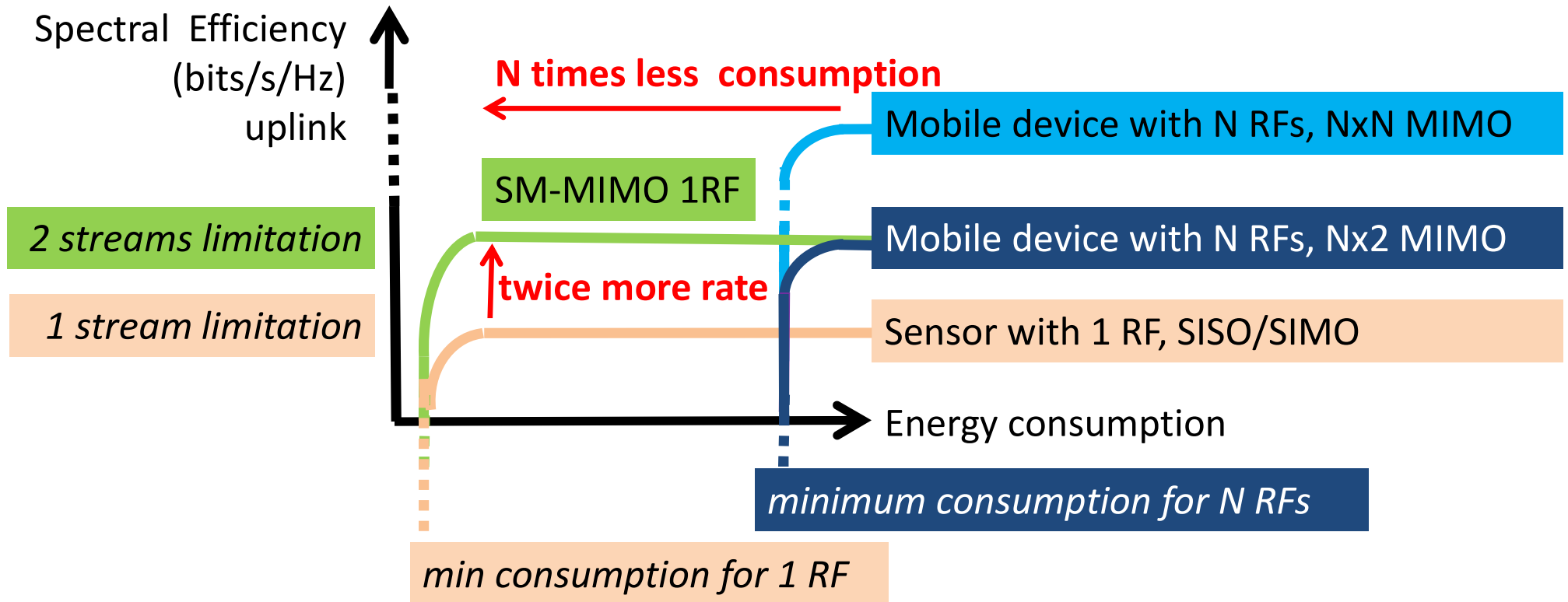

Spatial Modulation:

Can we Increase the Data Rate of IoT Devices Without Increasing their Power Consumption and Complexity ?

Spatial Modulation – In a Nutshell...

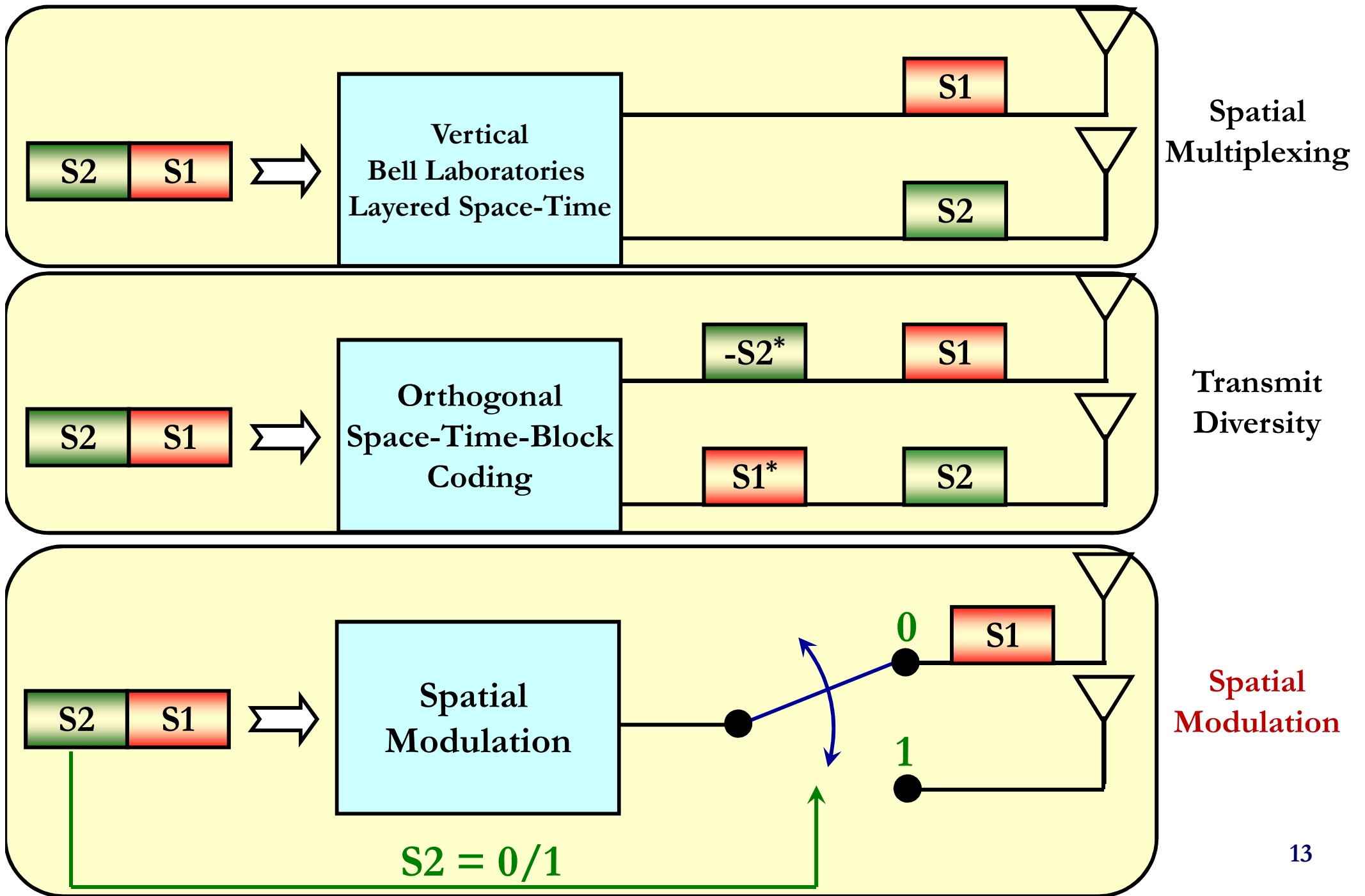

Spatial Modulation – How It Works?

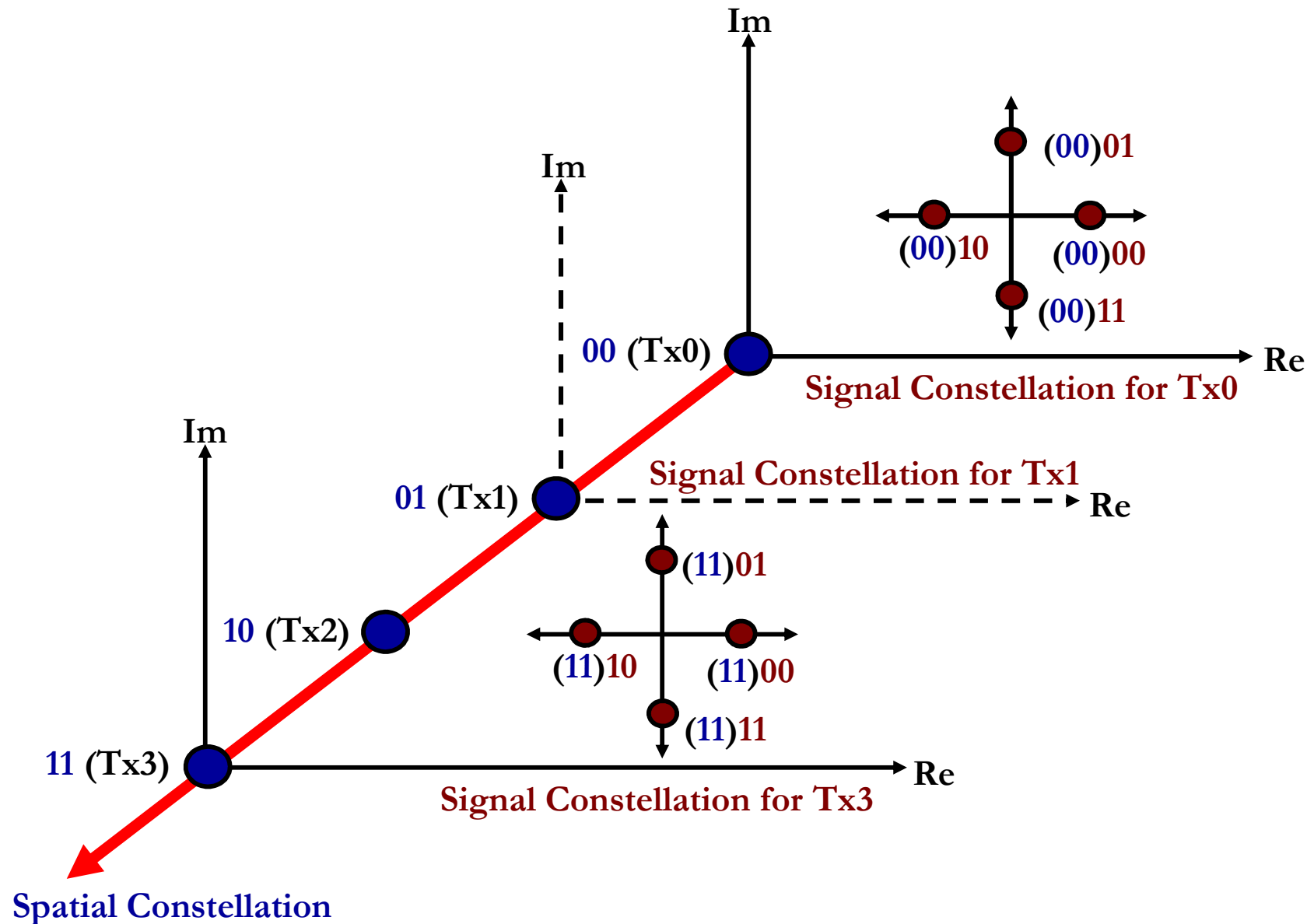

Spatial Modulation – How It Works?

... 1110 0001 ...

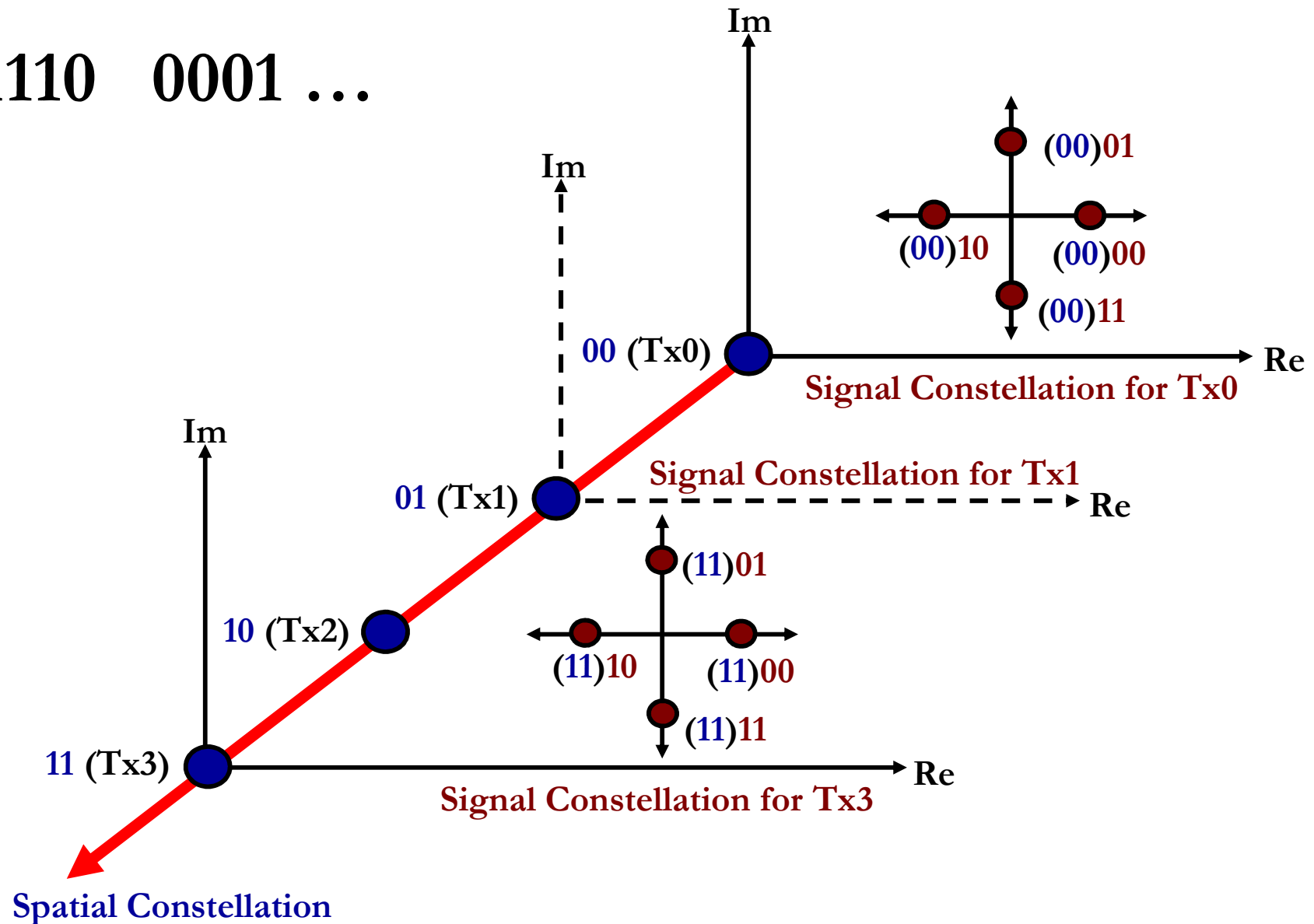

Spatial Modulation – How It Works?

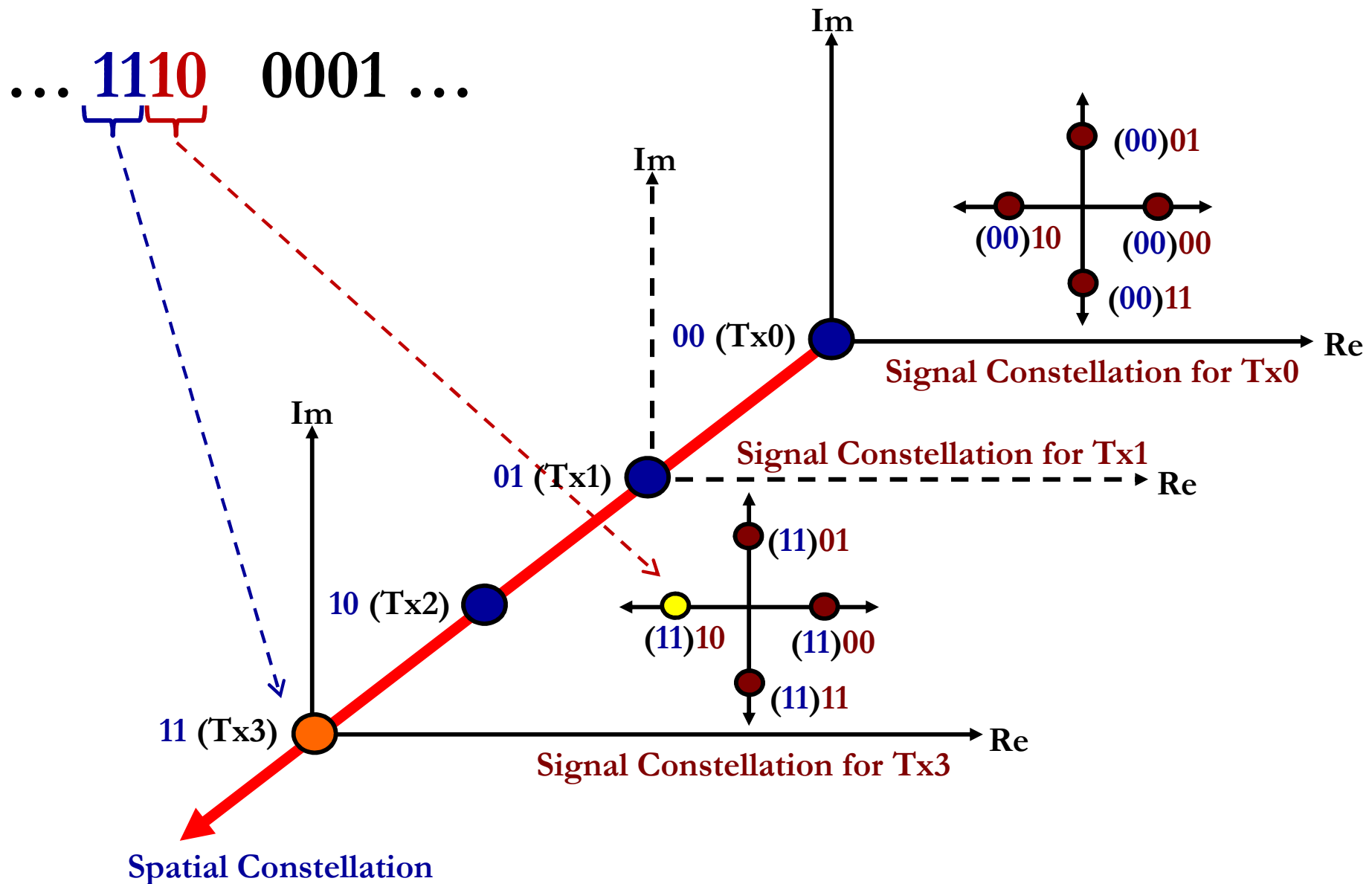

Spatial Modulation – How It Works?

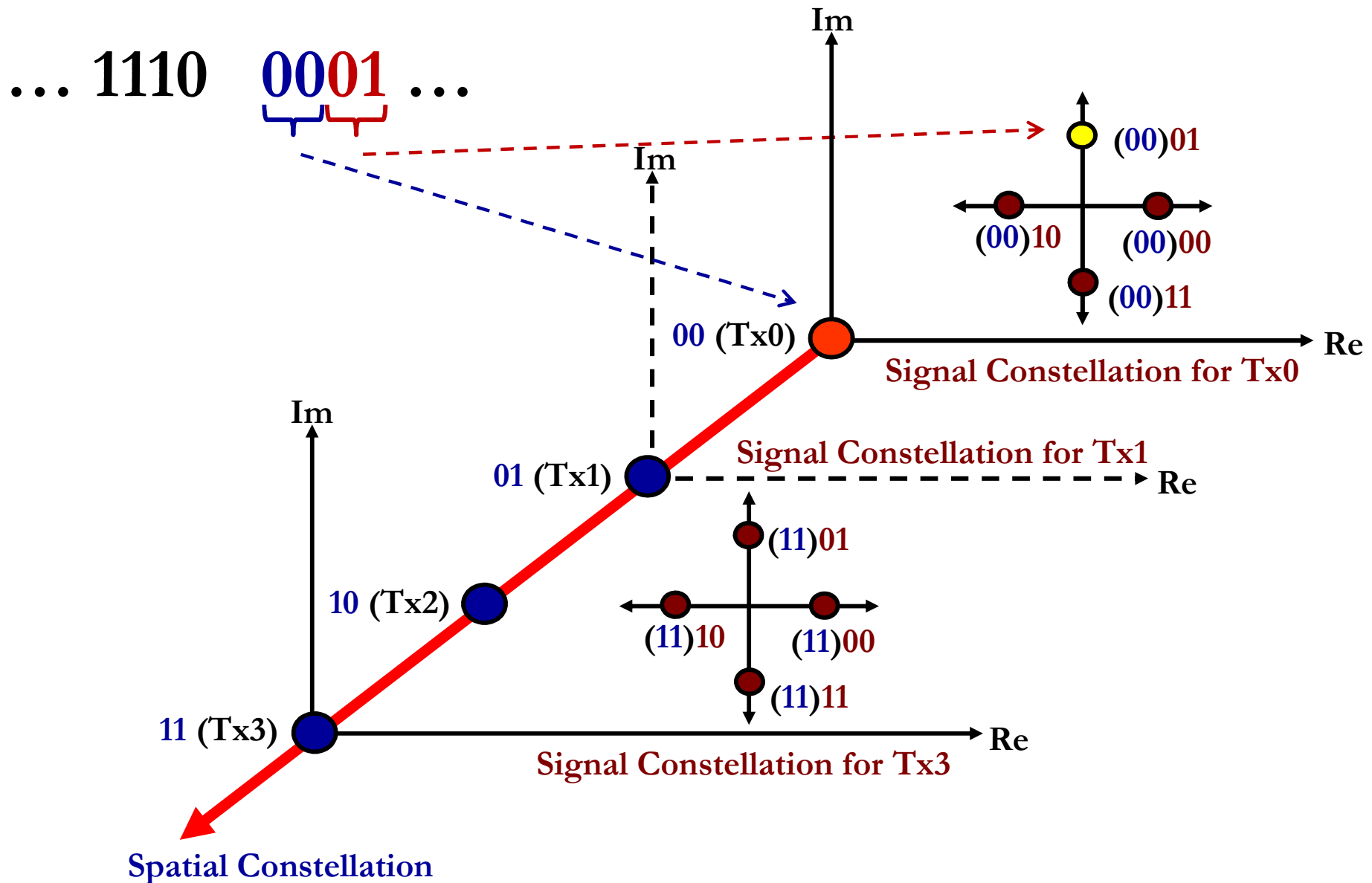

Spatial Modulation – High Energy Efficiency

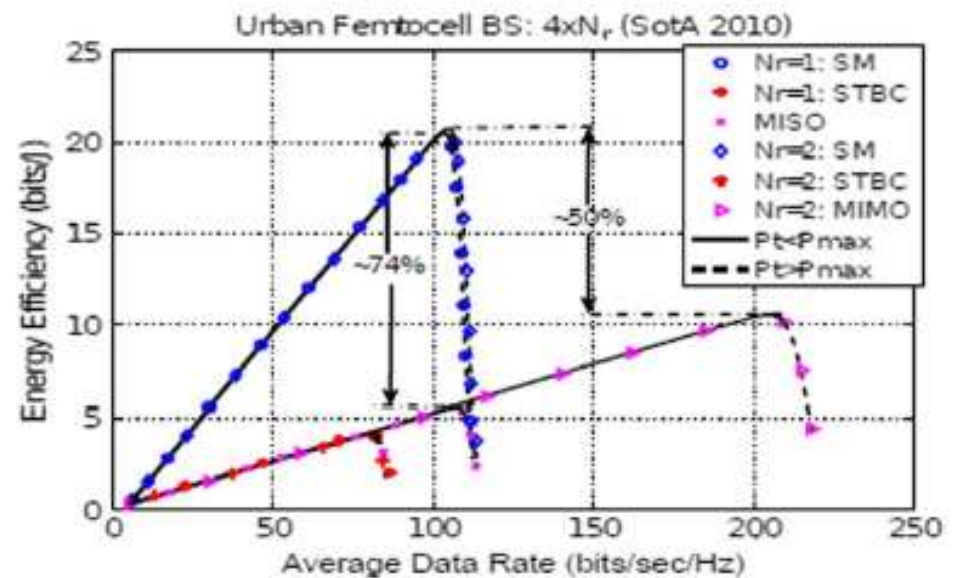
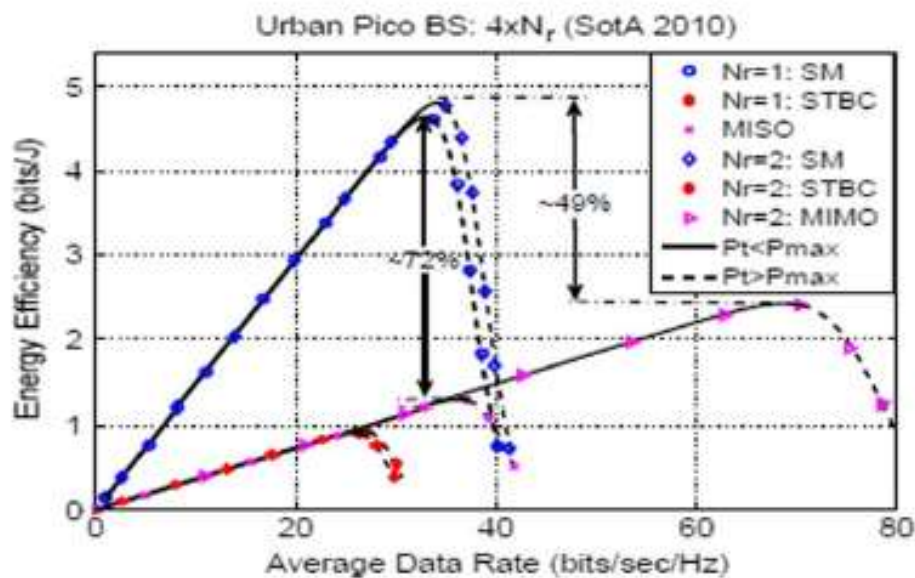
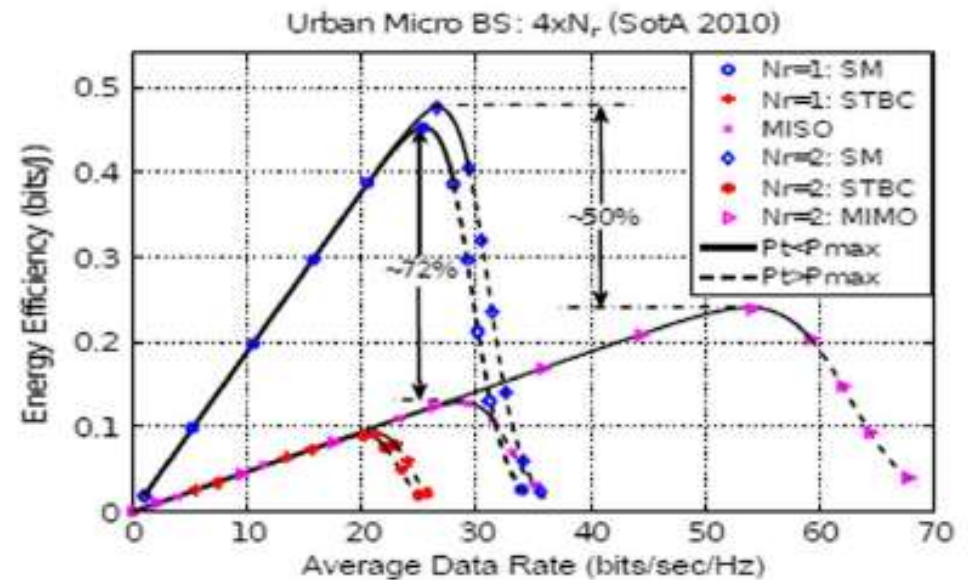
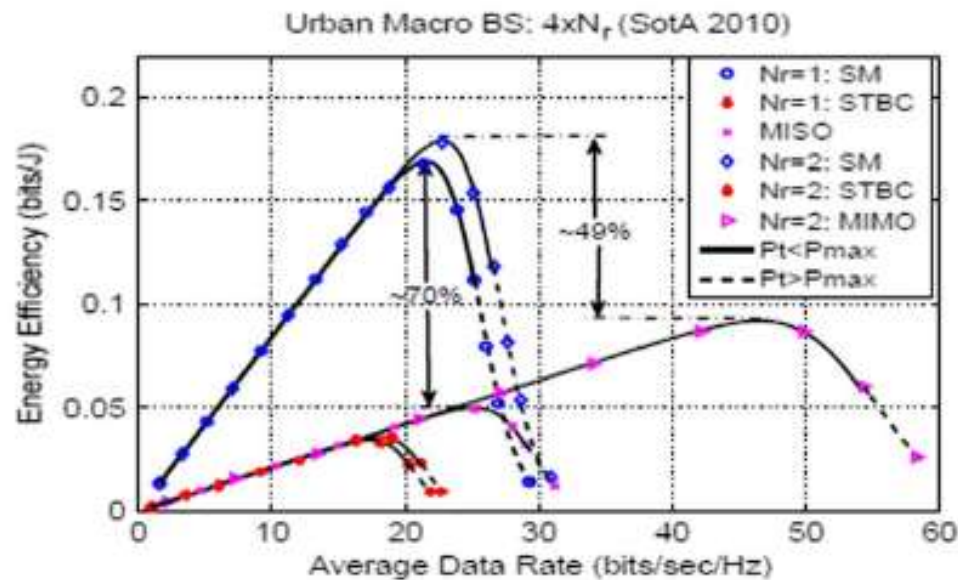

The ANR Spatial Modulation Project...

Objective: To deliver high data rate in connected objects

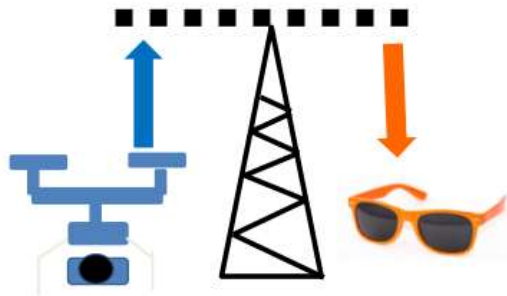

Base Station: Massive MIMO + **Advanced** signal processing

5G links

Object: **Miniature** antenna(s) + **Simple** signal processing

Visual demonstration of Transmit Spatial Modulation

Object transmits with the rate of 2 antennas but has the cost and consumption of 1 antenna

base station

object

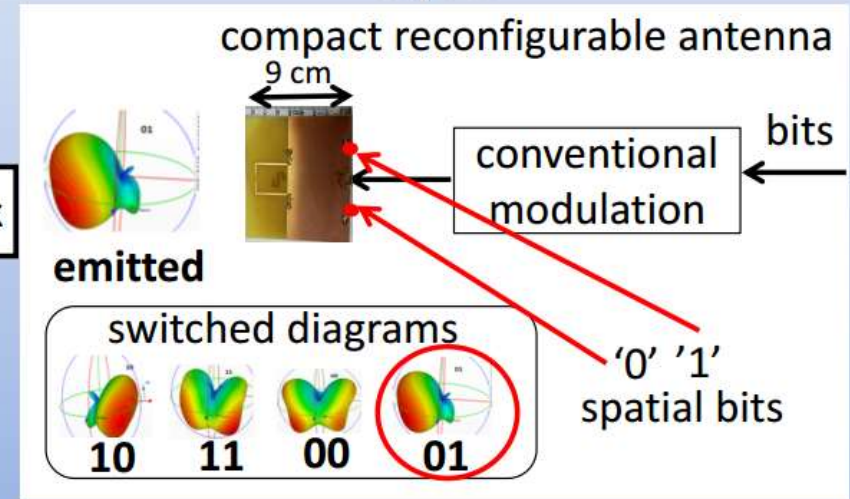
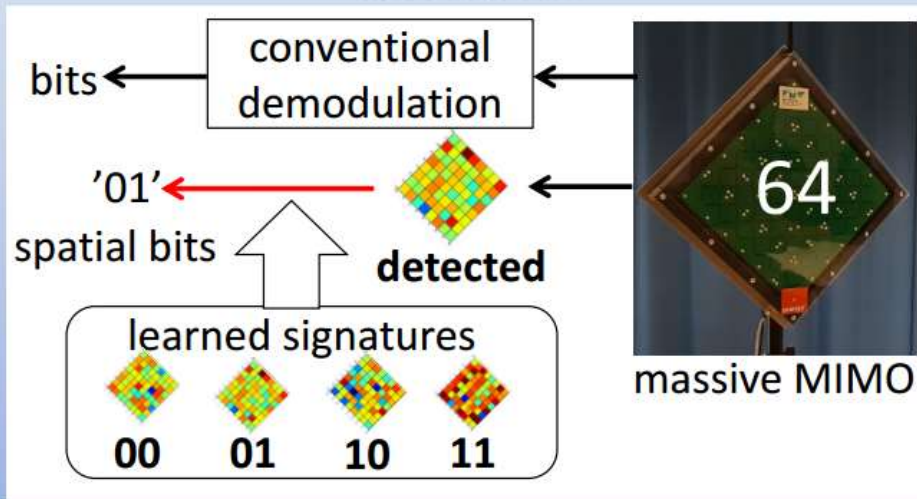

4-State Mono-Port Reconfigurable Antenna

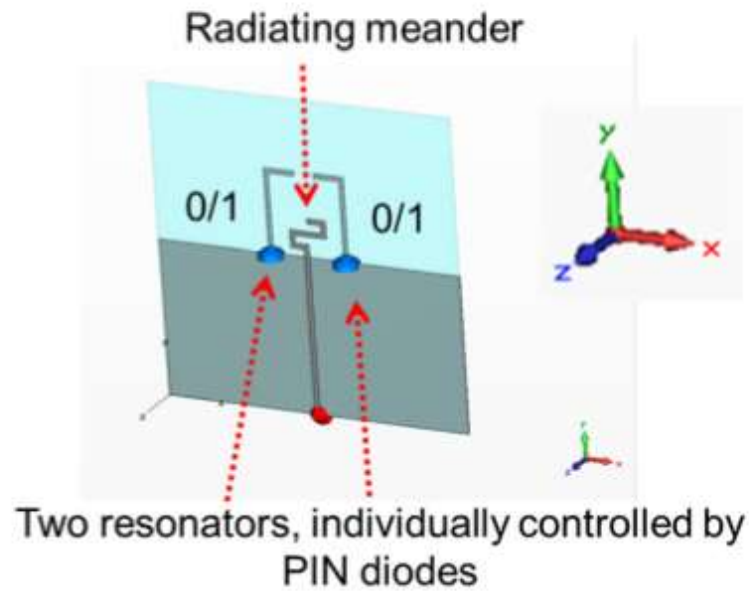

a) Antenna

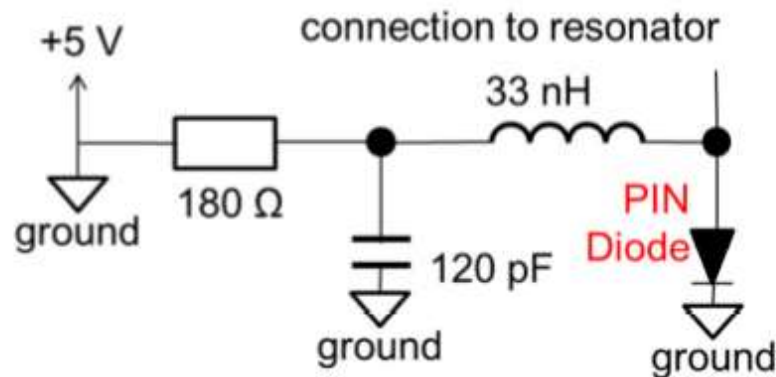

a) PIN diode based switching system

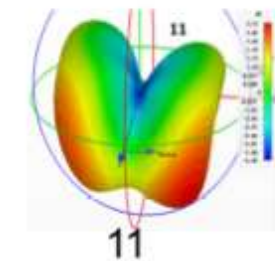
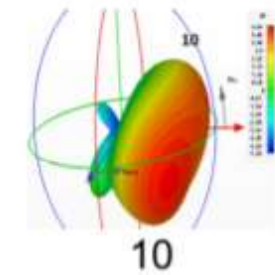
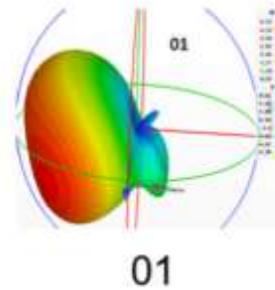
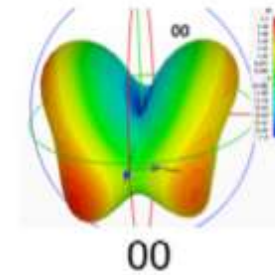

c) Antenna diagrams

8-State Mono-Port Reconfigurable Antenna

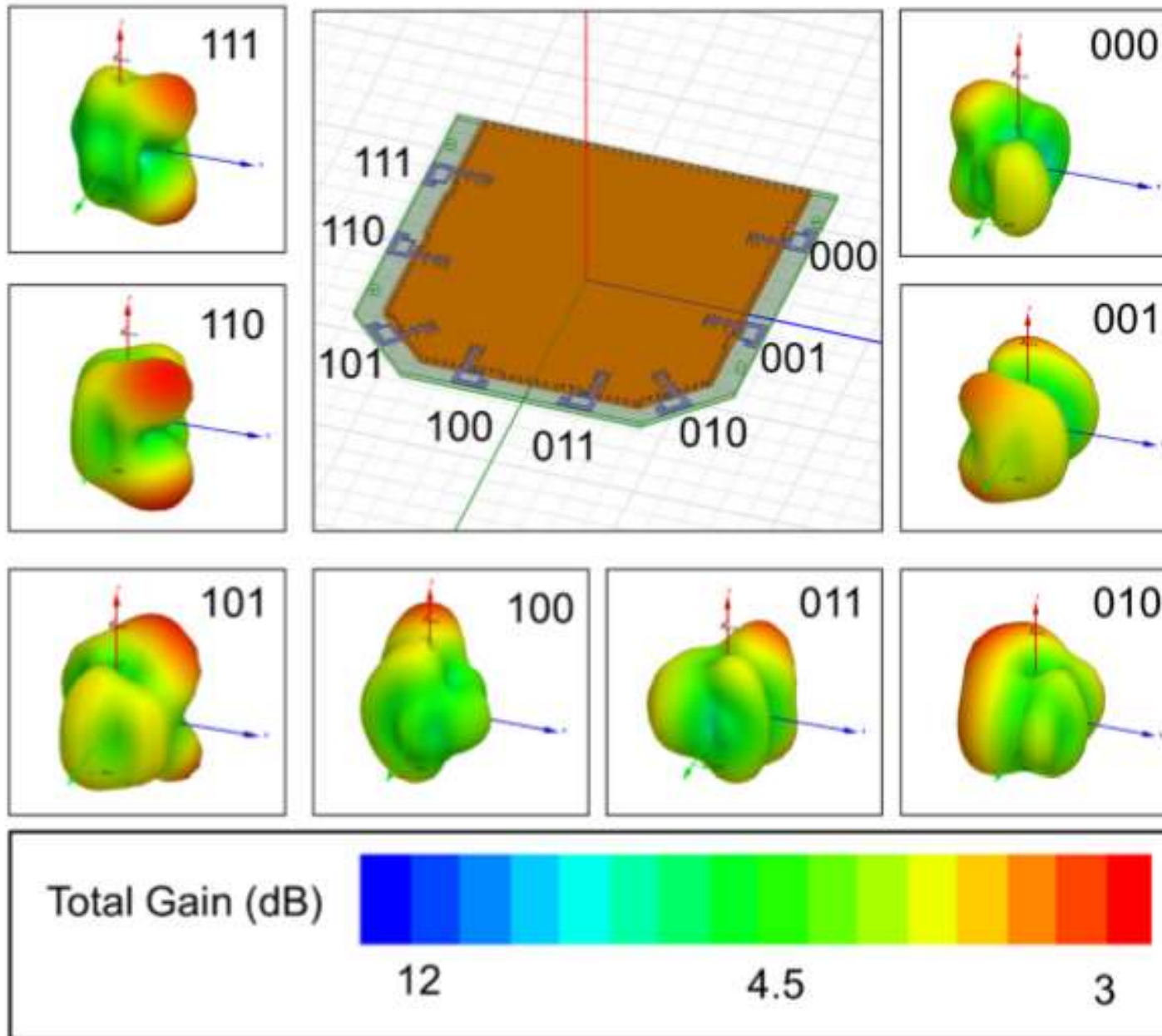

IEEE ICC 2017, Paris, France



IEEE International Conference on Communications
18-22 may 2017, Paris
Spatial modulation demonstration



Spatial Modulation

Project leader : dinhthuy.phanhuy@orange.com
<https://spatmodulation.cms.orange-labs.fr/>



IEEE ICC 2017, Paris, France

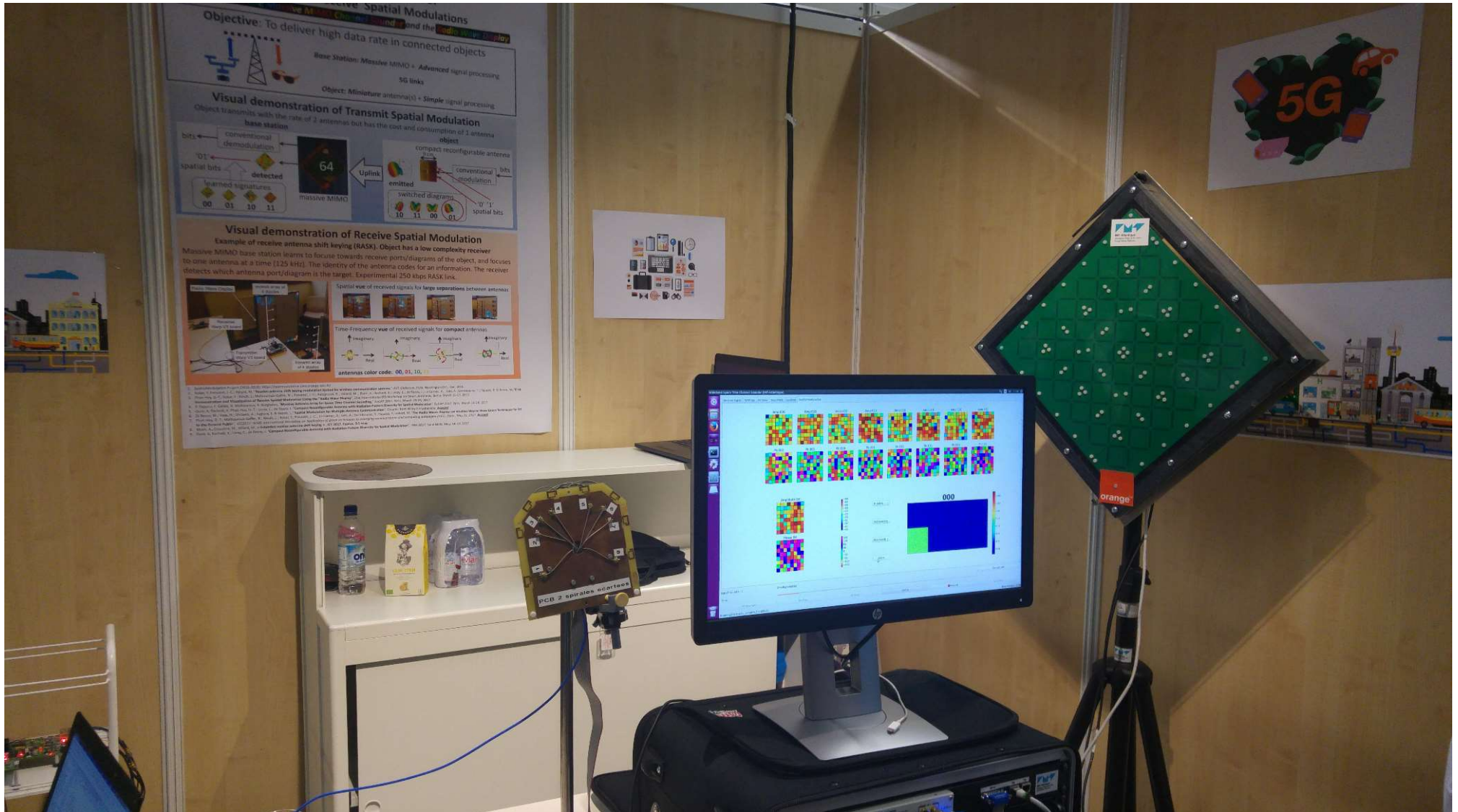

IEEE ICC 2017, Paris, France

TX array (8 antennas)
with switching unit

Transmitter (pure tone)

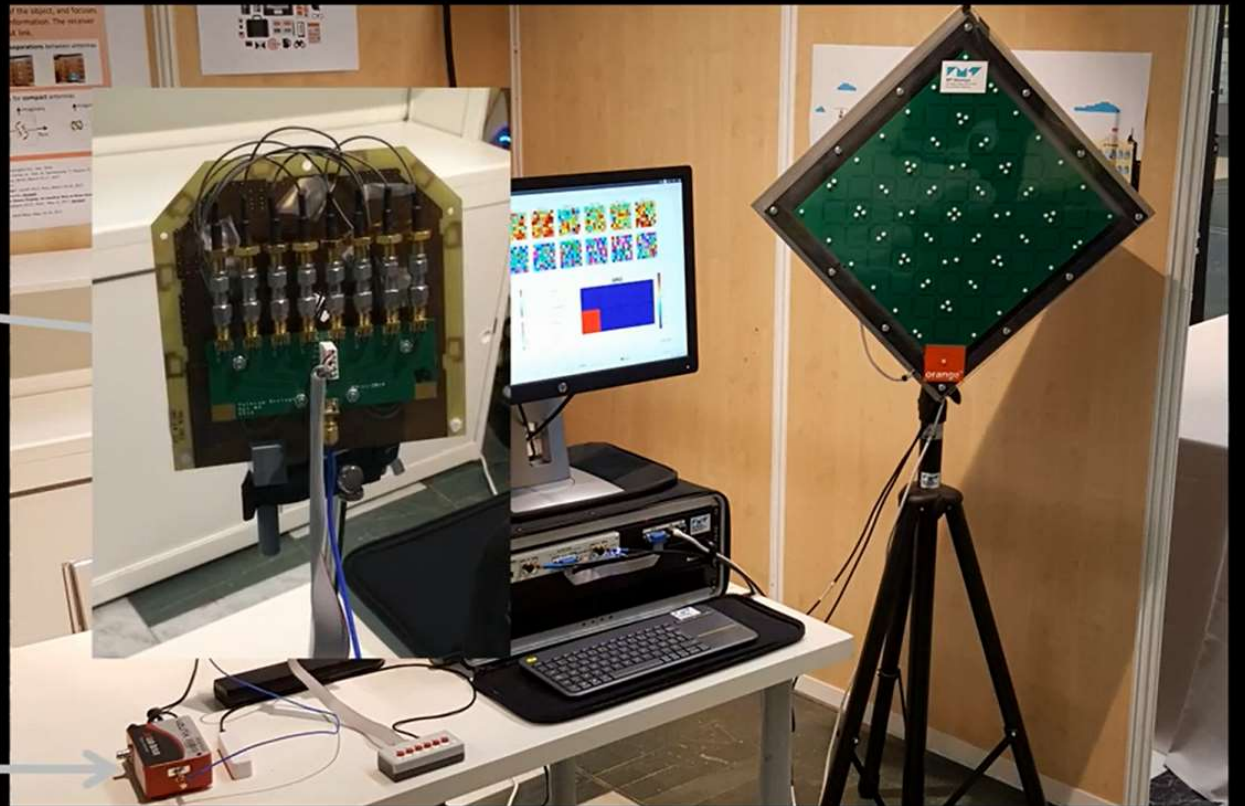

IEEE ICC 2017, Paris, France



IEEE ICC 2017, Paris, France: Watch The Video



IEEE International Conference on Communications
18-22 may 2017, Paris
Spatial modulation demonstration



Project leader : dinhthuy.phanhuy@orange.com
<https://spatmodulation.cms.orange-labs.fr/>



<https://www.youtube.com/watch?v=L7xAeU2jh5s>

First Visual Demonstration of Transmit and Receive Spatial Modulations Using the “Radio Wave Display”

D.-T. Phan-Huy¹, Y. Kokar², J. Rioult^{3*}, N. Malhouroux-Gaffet¹, J.-C. Prévotet², C. Buey¹, P. Ratajczak¹, M. Héliard², A. Ourir⁵, K. Rachedi⁵, C. Leray⁶, J. de Rosny⁵, Le Cornec¹, A. Gati¹, T. Sarrebourg¹, P. Pajusco⁴, M. Di Renzo⁷
¹Orange Labs, ²INSA-Rennes, ³Ifsttar, Luxondes^{*}, ⁴IMT Atlantique, ⁵ESPCI, ⁶ATOS, ⁷Centrale-Supélec, France
{dinhthuy.phanhuy, nadine.malhouroux, cyril.buey, philippe.ratajczak, alain.lecornec, azeddine.gati, thierry.sarrebourg}@orange.com, jean.rioult@ifsttar.fr, {yvan.kokar, Jean-Christophe.Prevotet, maryline.helard}@insa-rennes.fr, patrice.pajusco@imt-atlantique.fr, {a.ourir, kammel.rachedi, julien.derosny}@espci.fr, christian.leray@atos.net, marco.direnzo@lss.supelec.fr

Abstract— In this paper, for the first time, visual demonstrations of new signal processing candidate techniques for the future fifth generation of mobile networks and the internet of things, called Transmit Spatial Modulation and Receive Spatial Modulation, respectively, are described. These techniques exploit

symbol period. The index of the current transmit antenna element codes for a binary information. If the array is composed of 2^K antenna elements, the data stream with spatial modulation bears K bits per symbol period. Other works on reconfigurable antennas [5,6], show that one can transport



The White Paper on Research Beyond 5G has been made public on the NetWorld 2020 web site

The NetWorld2020 Expert Advisory Group has drafted a White Paper on the topic of Research Beyond 5G. You can download it [here](#).

The Expert Group is now inviting the NetWorld2020 community, and any interested stakeholder, to participate in a public consultation on the draft whitepaper. The objective is to collect feedback from the community. Based on the received feedback the document will be updated and finalised, followed by an endorsement process within the ETP.

Comments can be submitted via a [webform](#). Deadline is 30 November 2015.

About NetWorld2020:

NetWorld2020 is the European Technology Platform for communications networks and services. Communications networks enable interaction between users of various types of equipment, either mobile or fixed; they are the foundation of the Internet. The NetWorld2020 European Technology Platform gathers players of the communications networks sector: industry leaders, innovative SMEs, and leading academic institutions.

3.2 Realizable Massive MIMO

Antenna Selection [Gao 2013] and Spatial Modulation [Renzo 2011] are two possibilities that, when combined with massive MIMO, allow the reduction of the number of radio-frequency (RF) chains associated with the antennas, with a positive impact on the system complexity and hardware cost, while preserving the system performance at a certain required level.

Samsung 5G Trials in November 2016...



Beijing China – November 09, 2016 - Samsung Electronics announced today it has successfully conducted 5G prototype trial in conjunction with China Mobile Research Institute (CMRI), which was a cooperation milestone between the two companies since Samsung became a member of China Mobile 5G Innovation Center in June 2016.

During the 5G trial test in Beijing, the key technologies like spatial modulation and FBMC (Filter Bank Multicarrier) are validated for the low-frequency (3.5GHz), the performance of throughput, outband emission are tested. With Samsung's ultra-high frequency 5G prototype system and devices powered by advanced beam forming technology, Samsung and China Mobile Research Institute sought to verify mmWave technology's performance and frequency characteristics jointly, including mobility, peak throughput, and multi-user scheduling capacity, as well as mmWave transmission at indoor, penetration loss, etc.

The Spatial Modulation Legacy...



greenet

GREENET

Project ID: 264759

Funded under: [FP7-PEOPLE](#)

An early stage training network in enabling technologies for GREEN radio

From 2011-01-01 to 2014-12-31, closed project

Project details

Total cost: EUR 4 230 443,93	Topic(s): FP7-PEOPLE-2010-ITN - Marie-Curie Action: "Initial Training Networks"
EU contribution: EUR 4 230 443,93	Call for proposal: FP7-PEOPLE-2010-ITN See other projects for this call
Coordinated in: Spain	Funding scheme: MC-ITN - Networks for Initial Training (ITN)

Objective

Current 4G vision envisages higher data rates and multi standard radio interfaces to provide all users with a continuous seamless connection. The large number of foreseen devices coupled with the surge in power requirements for future emerging handsets raises significant challenges in terms of: i) reducing the energy consumption; and ii) reducing the amount of electromagnetic radiations. GREENET targets the following main objectives: 1. Recruitment of ESRs with the clear an...

World's First Measurements & Prototype (back in 2013)

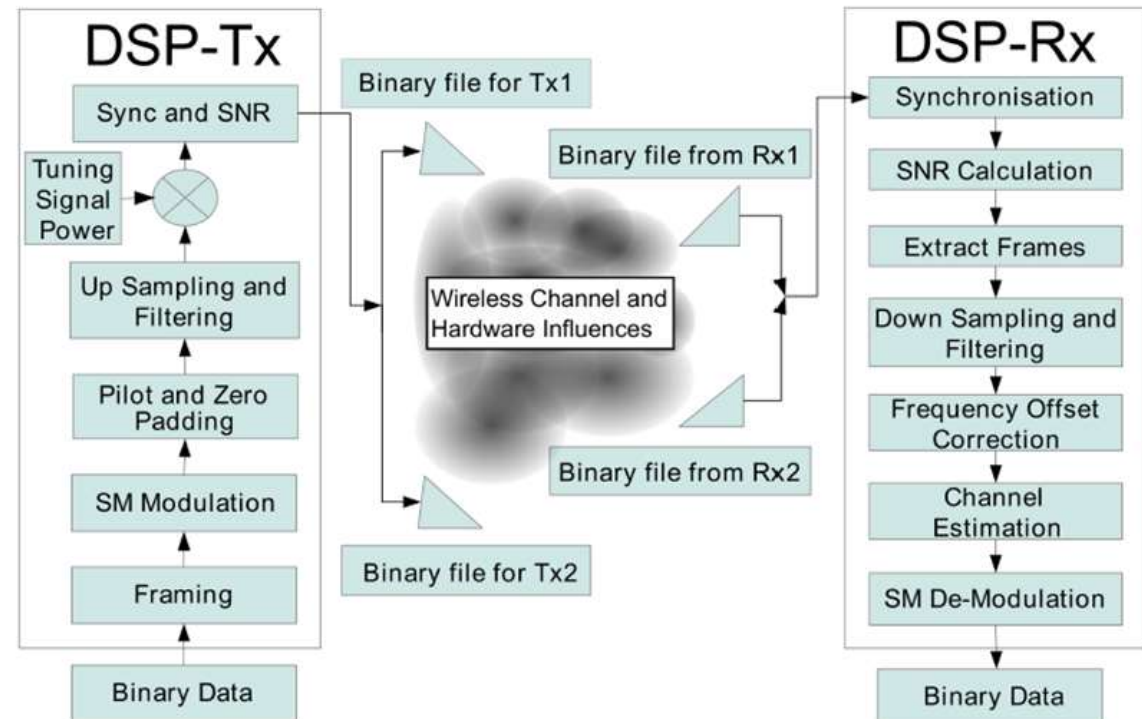
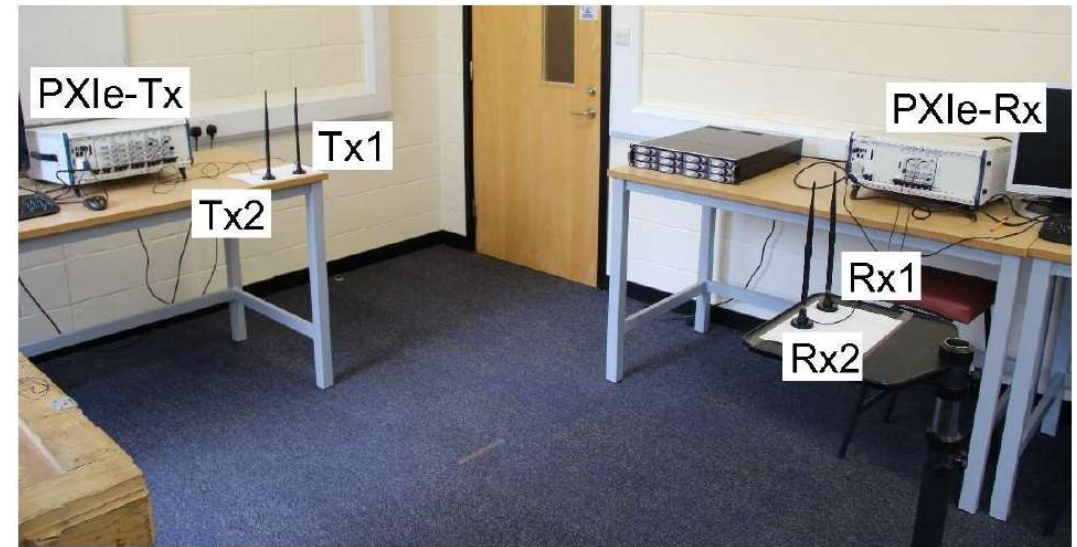
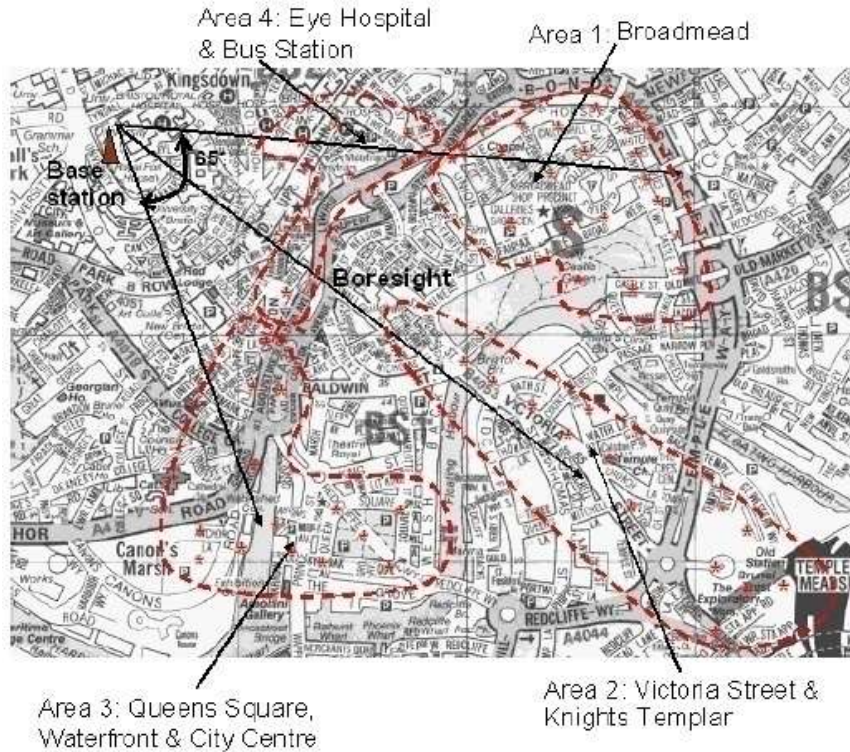

... and Current EU Activities: H2020-5Gwireless



5G Wireless

Project ID: 641985

Funded under: [H2020-EU.1.3.1. - Fostering new skills by means of excellent initial training of researchers](#)

Innovative Architectures, Wireless Technologies and Tools for High Capacity and Sustainable 5G Ultra-Dense Cellular Networks

From 2015-01-01 to 2018-12-31, ongoing project

Project details

Total cost:

EUR 3 858 492,24

EU contribution:

EUR 3 858 492,24

Coordinated in:

France

Topic(s):

[MSCA-ITN-2014-ETN - Marie Skłodowska-Curie Innovative Training Networks \(ITN-ETN\)](#)

Call for proposal:

H2020-MSCA-ITN-2014 [See other projects for this call](#)

Funding scheme:

MSCA-ITN-ETN - European Training Networks



Getting Intrigued... ? – Our Survey Papers...

- ❑ M. Di Renzo, H. Haas, and P. M. Grant, “Spatial Modulation for Multiple-Antenna Wireless Systems - A Survey”, **IEEE Commun. Magazine**, Vol. 49, No. 12, pp. 182-191, Dec. 2011.

- ❑ M. Di Renzo, H. Haas, A. Ghayeb, S. Sugiura, and L. Hanzo, “Spatial Modulation for Generalized MIMO: Challenges, Opportunities and Implementation”, **Proc. of the IEEE**, Vol. 102, No. 1, pp. 56-103, Jan. 2014.



- ❑ P. Yang, M. Di Renzo, Y. Xiao, S. Li, and L. Hanzo, “Design Guidelines for Spatial Modulation”, **IEEE Commun. Surveys & Tutorials**, Vol. 17, No. 1, pp. 6-26, Mar. 2015.

- ❑ P. Yang, M. Di Renzo, et al., “Single-Carrier SM-MIMO: A Promising Design for Broadband Large-Scale Antenna Systems”, **IEEE Commun. Surveys & Tutorials**, Vol. 18, No. 3, pp. 1687-1716, July 2016.

- ❑ M. Di Renzo, H. Haas, A. Ghayeb, S. Sugiura, and L. Hanzo, “Spatial Modulation for Multiple-Antenna Communication”, **Wiley Encyclopedia of the IEEE**, Nov. 2016.

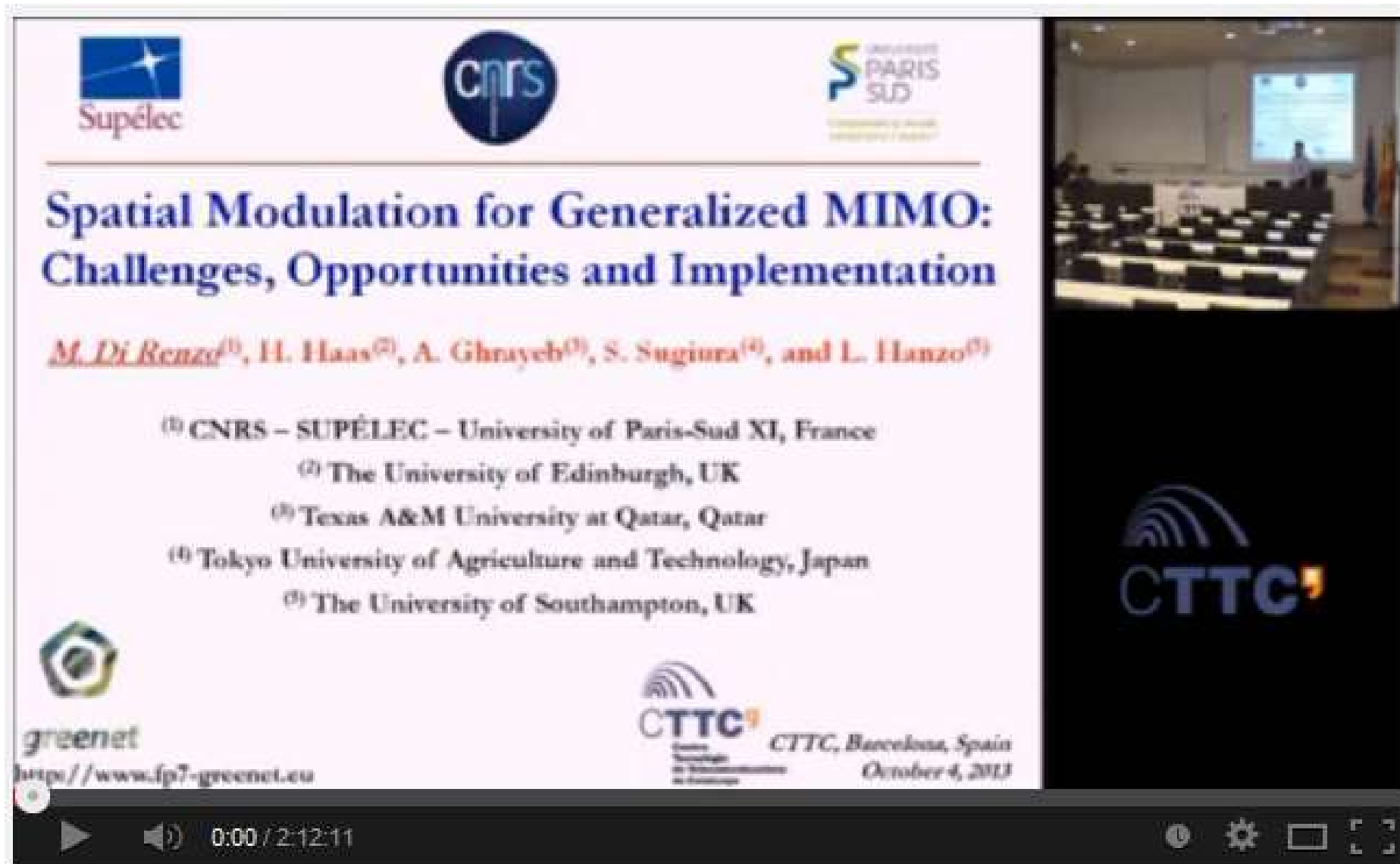
Getting Intrigued... ? – Our 2-hour Tutorial...





Spatial Modulation for Generalized MIMO: Challenges, Opportunities and Implementation

M. Di Renzo⁽¹⁾, H. Haas⁽²⁾, A. Ghayeb⁽³⁾, S. Sugiura⁽⁴⁾, and L. Hanzo⁽⁵⁾

⁽¹⁾ CNRS – SUPÉLEC – University of Paris-Sud XI, France
⁽²⁾ The University of Edinburgh, UK
⁽³⁾ Texas A&M University at Qatar, Qatar
⁽⁴⁾ Tokyo University of Agriculture and Technology, Japan
⁽⁵⁾ The University of Southampton, UK

  *CTTC, Barcelona, Spain*
October 4, 2013

 *greenet*
<http://www.fp7-greenet.eu>

0:00 / 2:12:11

<https://youtu.be/cNgCJK4oimM>

IEEE Access – We Are Accepting Papers...

IEEE Access[®]

Multidisciplinary : Rapid Review : Open Access Journal



Special Section: Call for Papers

Announcing a Special Section in **IEEE Access**:

INDEX MODULATION TECHNIQUES FOR NEXT-GENERATION WIRELESS NETWORKS

Submission Deadline: 31 August 2017

IEEE Access invites manuscript submissions in the area of Index Modulation Techniques for Next-Generation Wireless Networks.

Associate Editor: Ertugrul Basar, Istanbul Technical University, Turkey

Guest Editors:

1. Miaowen Wen, South China University of Technology, China.
2. Read Mesleh, German Jordan University in Amman, Jordan
3. Marco Di Renzo, Paris-Saclay University, France.
4. Yue Xiao, University of Electronic Science and Technology of China, China.
5. Harald Haas, University of Edinburg, UK.

Relevant IEEE Access Special Sections:

- 1) Future Networks: Architectures, Protocols, and Applications
- 2) Physical and Medium Access Control Layer Advances in 5G Wireless Networks
- 3) Wireless Caching Technique for 5G

IEEE Access Editor-in-Chief: Michael Pecht, Professor and Director, CALCE, University of Maryland

Thank You for Your Attention



- **ANR-SpatialModulation (French Science Foundation)**
Spatial Modulation & reconfigurable antenna to provide high rate connectivity to mobile & energy autonomous IoT devices
(Jan. 2016 – Jun. 2019) - <https://spatmodulation.cms.orange-labsfr/>



Marco Di Renzo, Ph.D., H.D.R.

Chargé de Recherche CNRS (Associate Professor)

Editor, IEEE Communications Letters

Editor, IEEE Transactions on Communications

Editor, IEEE Transactions on Wireless Communications

Distinguished Lecturer, IEEE Communications Society

Distinguished Lecturer, IEEE Vehicular Technol. Society

Paris-Saclay University

Laboratory of Signals and Systems (L2S) – UMR-8506

CNRS – CentraleSupélec – University Paris-Sud

3 rue Joliot-Curie, 91192 Gif-sur-Yvette (Paris), France

E-Mail: marco.direnzo@l2s.centralesupelec.fr

université
PARIS-SACLAY



CentraleSupélec



Comprendre le monde,
construire l'avenir®