

5G-PICTURE

5G Programmable Infrastructure Converging
disaggregated neTwork and compUte Resources

Anna Tzanakaki (University of Bristol, UK, NKUA, Greece)

Consortium

- IHP GmbH (Coordinator)
- University of Bristol
- ADVA Optical Networking
- Airrays GmbH
- Blu Wireless Technology
- CNIT
- COSMOTE
- EURECOM
- Fundació Privada i2CAT, Internet I Innovació Digital a Catalunya
- Telecom Italia S.p.A
- Zeetta Networks



- Mellanox
- Huawei Technologies Dusseldorf GmbH
- Technische Universität Dresden
- Transpacket
- Paderborn University
- COMSA INSTALACIONES Y SISTEMAS INDUSTRIALES SL
- Ferrocarrils de la Generalitat de Catalunya
- University of Thessaly

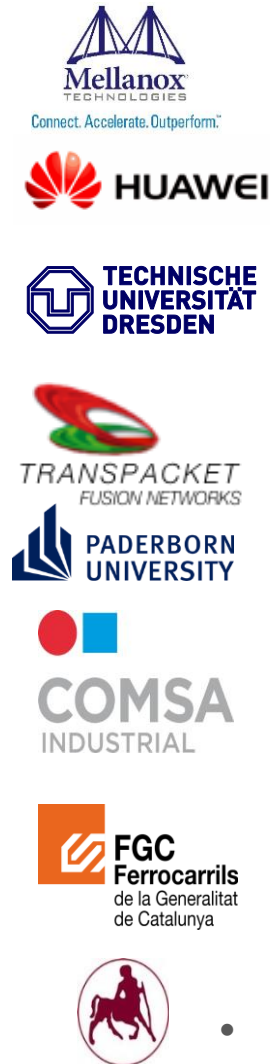

- Universities (4x), Research Institutes (4x), SMEs (3x), Operators (3x), Industry partners (5x)

- 30 months duration
- Start: 01/06/2017
- 7.99 million euro EU funding 2



5G-PICTURE Main Objectives

- 5G-PICTURE will design and develop an integrated, scalable and open 5G infrastructure with the aim to support a variety of ***operational*** and ***end-user services*** for both ***ICT*** and ***“vertical” industries***.
- This infrastructure will rely on a ***converged fronthaul*** and ***backhaul*** solution, integrating advanced wireless access and novel optical network domains.
- 5G-PICTURE will rely on ***network softwarisation*** to enable an open reference platform instantiating a variety of ***network functions*** over a ***unified operating platform***
 - ***slicing*** and ***service chaining*** to facilitate optimised **multi-tenant operational models**



Concept

- 5G-PICTURE proposes to integrate network and compute/storage resources in a common infrastructure.
- To address the limitations of current solutions 5G-PICTURE will adopt the novel concept of ***Disaggregated-Radio Access Networks*** (DA-RANs)
 - allows any service to flexibly ***mix-and-match*** and use ***compute***, storage and ***network resources*** through ***HW programmability***
 - relies on network ***softwarisation*** to enable an open reference platform instantiating a variety of network functions
 - adopts ***slicing*** and ***service chaining*** to facilitate optimised ***multi-tenancy*** operation
- Hierarchical compute & storage structure supported by a network hierarchy
- Integrated programmable wireless technologies at the edge and a hybrid passive/active optical transport network



Technical Approach

- To address the limitations of D-RAN and C-RAN will develop flexible functional splits
- Adoption of the notion of DA-RAN relying on resource disaggregation
 - mixing-and-matching of resources
- Development of novel technology solutions and control & management platforms
 - enhanced network and compute HW and SW modularity and flexibility
- Creation and deployment of programmable network functions and intelligent orchestration schemes
 - service chaining
 - slicing & multi-tenancy

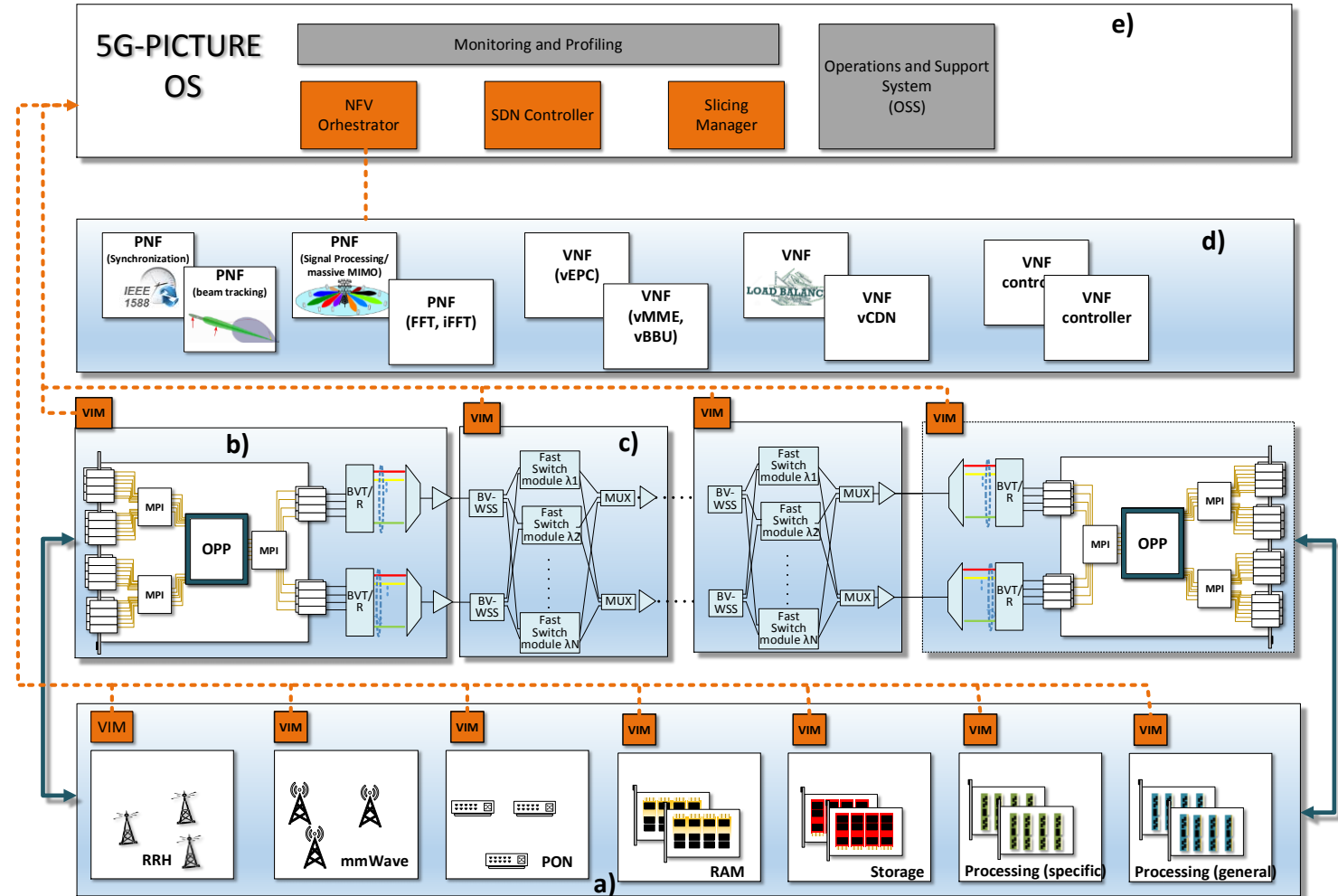

Overall Infrastructure

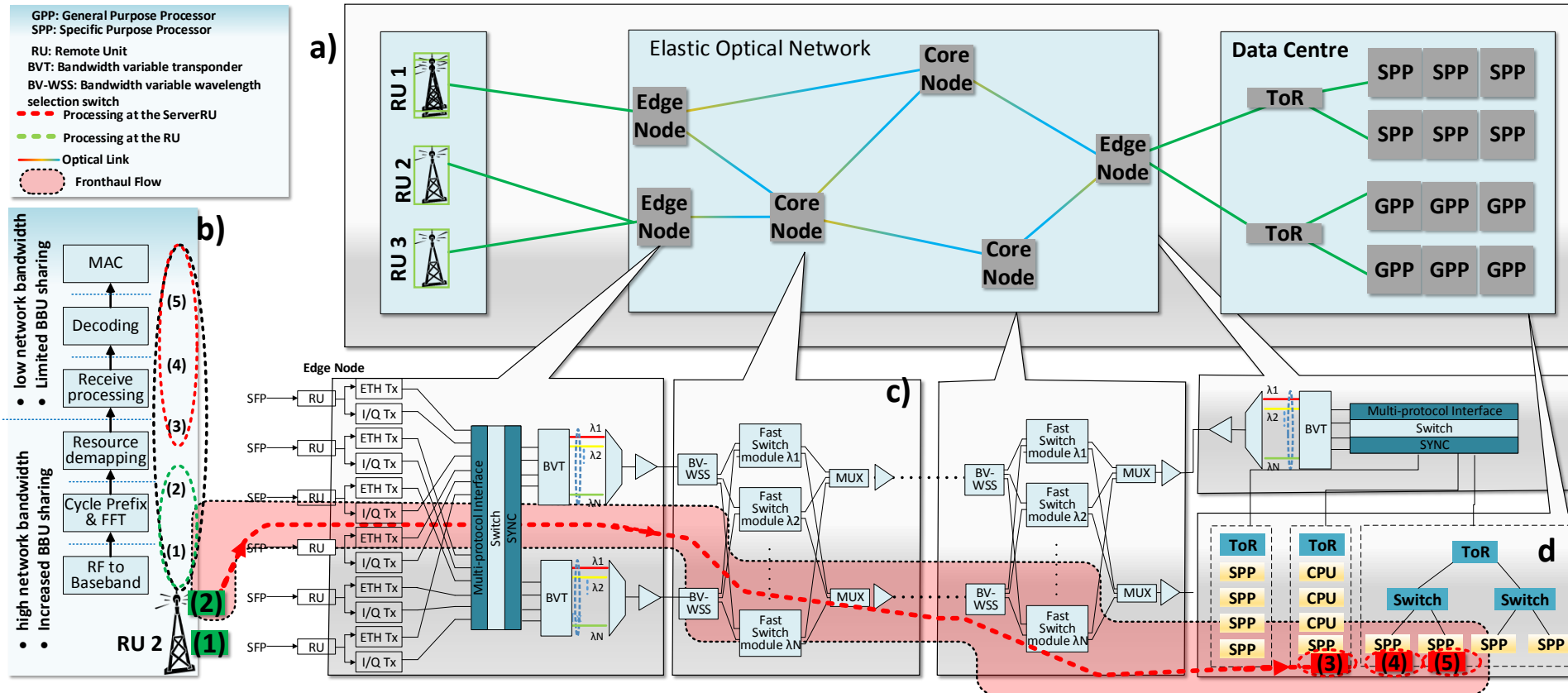

- Key Challenge:
 - Converged Fronthaul and Backhaul Services
 - Converged Network and Compute Services
 - Disaggregation of Resources

Physical Network Infrastructure

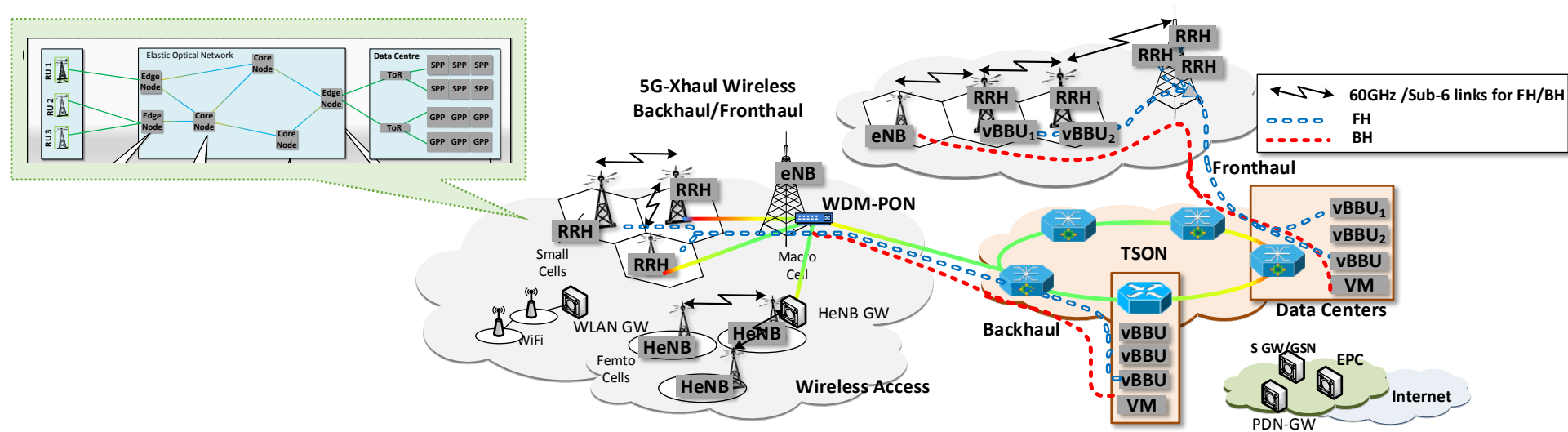

- Integrated optical and wireless network infrastructure for transport and access capitalising the **5G-Xhaul physical infrastructure**
- Wireless domain:
 - Dense layer of small cells complemented by macro cells to ensure ubiquitous coverage
 - Small cells can be backhauled to the macro-cell site either wirelessly using a combination of mm-Wave and sub-6 wireless technologies or using a hybrid optical network platform
- Optical Domain
 - Adoption of a dynamic and flexible/elastic frame based optical network solution combined with enhanced capacity WDM PONs
- BB Processing: RUs are connected to remote BB processing pools through high bandwidth transport links

Convergence of Networking and Computation

- Fronthaul adopting flexible functional splits
 - Transport Network and Compute Resources
 - Processing parallelisation
 - Full GPP with commodity hardware and hybrid solutions
- Disaggregation of Network and Compute resources
 - Mixing and matching of resources to efficiently support services

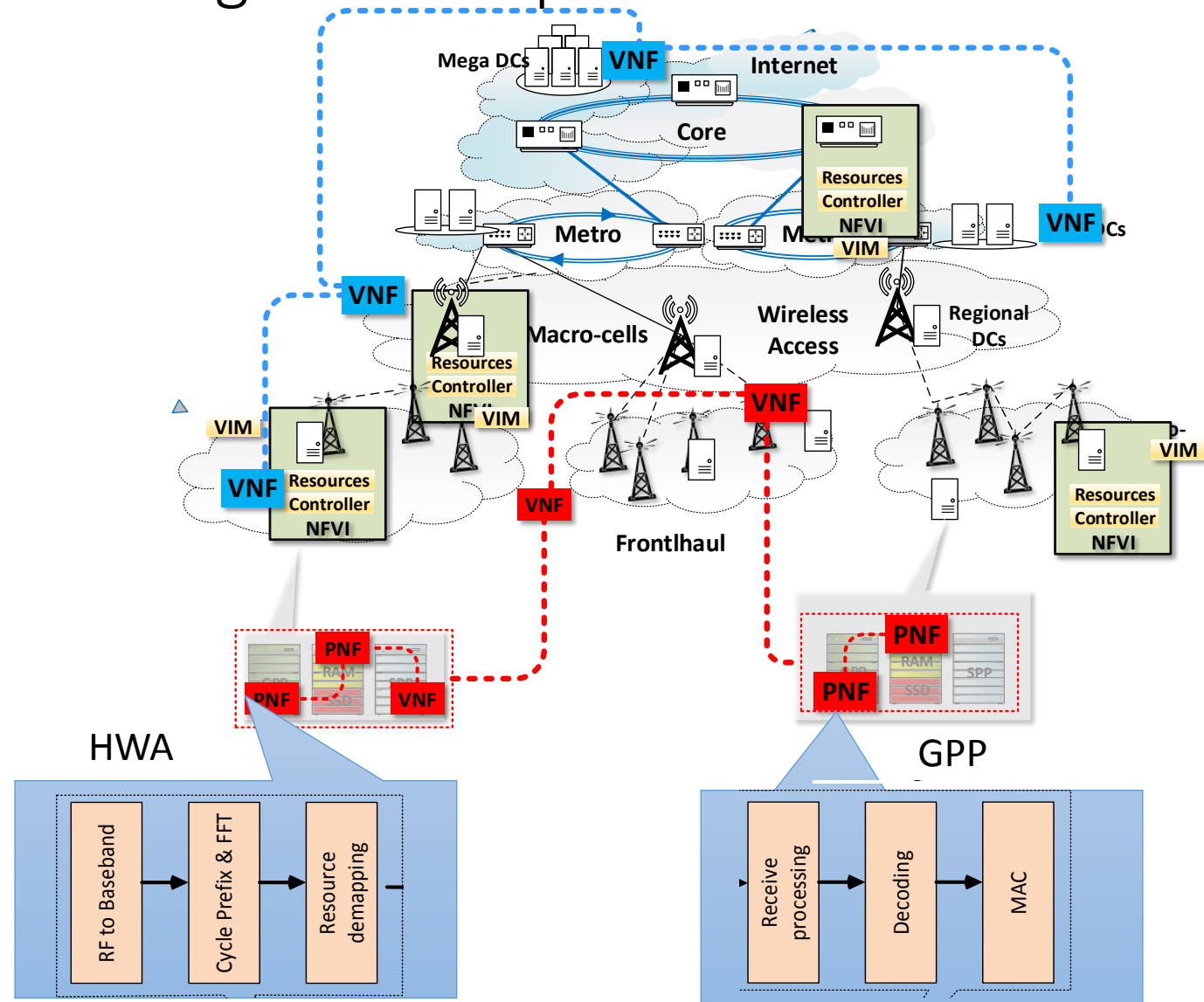

Processing Parallelization

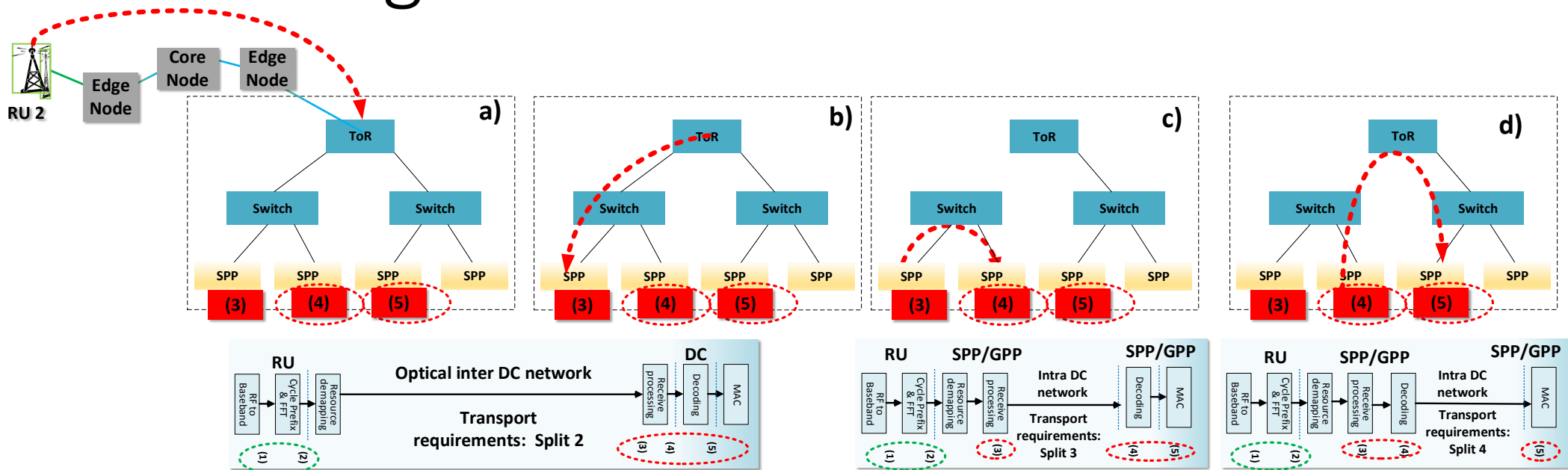

- BBU sub-frame processing time < 1ms
- To reduce processing delay, BB processing is handled in parallel over disaggregated compute resources
- Model 1: parallel (or sequential) processing mode
 - each function is distributed across DC multiple processing units (1:N)
- Model 2: Pipelining
 - each processing unit handles a specific function adopting 1:1 mapping

Validation - Demo Activities

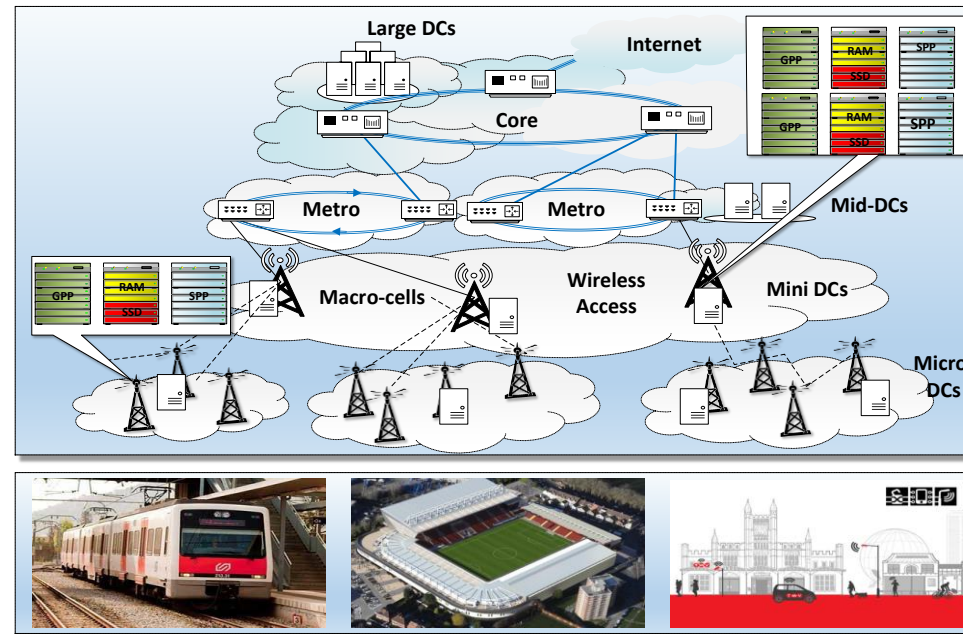

- Extensive demonstration activities to showcase ICT and vertical industry use cases
 - Converged fronthaul and backhaul services in a smart city test-bed (city of Bristol, UK)
 - Seamless service provisioning and mobility management in high speed railway environments - 5G railway experimental testbed (FGC, Barcelona, Spain)
 - Media services supporting large venues with increased density and static-to-low mobility - stadium test-bed supporting large venues (Bristol, UK)

UK 5G Trials Programme

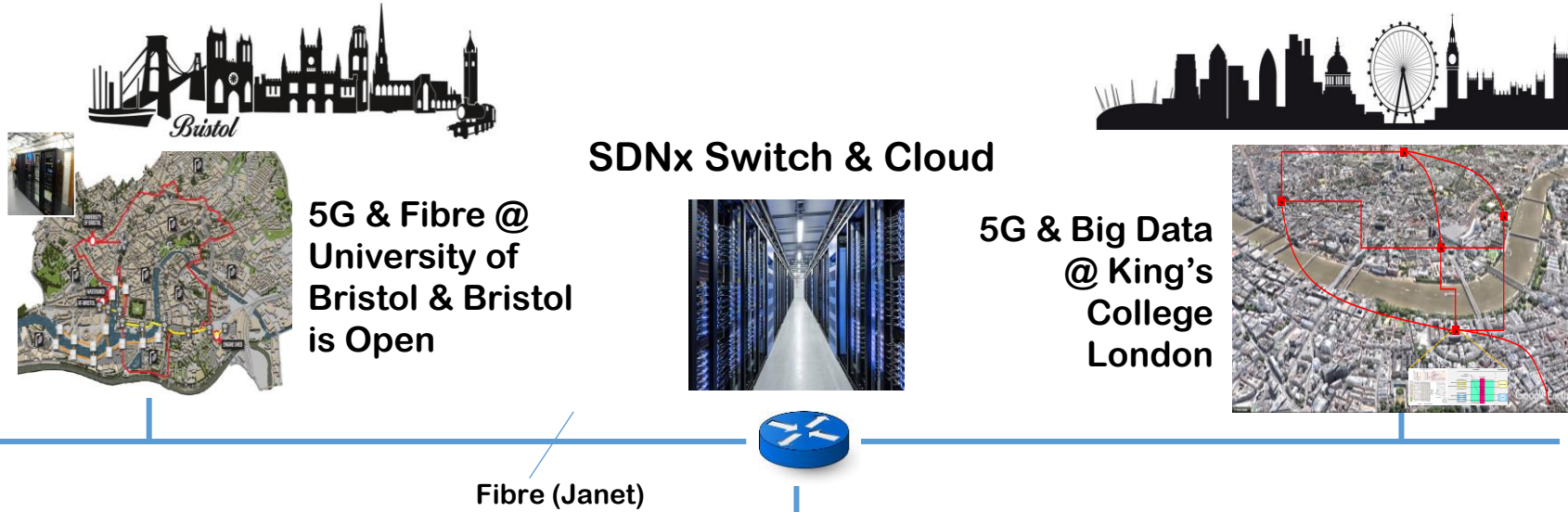

5G Consumer Use-Cases

This block shows three consumer use-cases for 5G: a tablet displaying a mobile game, a person wearing a VR headset, and a smartwatch.

5G @ 5GIC, University of Surrey

This block features a map of the University of Surrey campus showing the 5G network layout. The map is overlaid with various logos of partner organizations, including Vodafone, BT, BT Sport, BT Sport 2, BT Sport 3, BT Sport 4, BT Sport 5, BT Sport 6, BT Sport 7, BT Sport 8, BT Sport 9, BT Sport 10, BT Sport 11, BT Sport 12, BT Sport 13, BT Sport 14, BT Sport 15, BT Sport 16, BT Sport 17, BT Sport 18, BT Sport 19, BT Sport 20, BT Sport 21, BT Sport 22, BT Sport 23, BT Sport 24, BT Sport 25, BT Sport 26, BT Sport 27, BT Sport 28, BT Sport 29, BT Sport 30, BT Sport 31, BT Sport 32, BT Sport 33, BT Sport 34, BT Sport 35, BT Sport 36, BT Sport 37, BT Sport 38, BT Sport 39, BT Sport 40, BT Sport 41, BT Sport 42, BT Sport 43, BT Sport 44, BT Sport 45, BT Sport 46, BT Sport 47, BT Sport 48, BT Sport 49, BT Sport 50, BT Sport 51, BT Sport 52, BT Sport 53, BT Sport 54, BT Sport 55, BT Sport 56, BT Sport 57, BT Sport 58, BT Sport 59, BT Sport 60, BT Sport 61, BT Sport 62, BT Sport 63, BT Sport 64, BT Sport 65, BT Sport 66, BT Sport 67, BT Sport 68, BT Sport 69, BT Sport 70, BT Sport 71, BT Sport 72, BT Sport 73, BT Sport 74, BT Sport 75, BT Sport 76, BT Sport 77, BT Sport 78, BT Sport 79, BT Sport 80, BT Sport 81, BT Sport 82, BT Sport 83, BT Sport 84, BT Sport 85, BT Sport 86, BT Sport 87, BT Sport 88, BT Sport 89, BT Sport 90, BT Sport 91, BT Sport 92, BT Sport 93, BT Sport 94, BT Sport 95, BT Sport 96, BT Sport 97, BT Sport 98, BT Sport 99, BT Sport 100. The text '5G @ 5GIC, University of Surrey' is centered below the map.

5G Industry Use-Cases

This block shows three industry use-cases for 5G: a retail store with customers, a surgical team in an operating room, and an autonomous delivery vehicle.



5G-PICTURE

Thanks for your attention!

5G-PICTURE Project

Project Coordinator:

Eckhard Grass (grass@ihp-microelectronics.com)

Technical Manager:

Anna Tzanakaki (Anna.Tzanakaki@bristol.ac.uk)

Project Website:

<http://www.5g-picture-project.eu/index.html>

Twitter:

https://twitter.com/5G_PICTURE

